

RATIOMETRIC, LINEAR HALL-EFFECT SENSORS

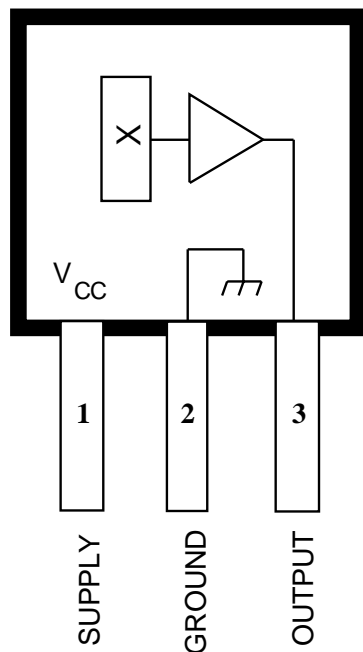

Dwg. PH-006

Pinning is shown viewed from branded side.

ABSOLUTE MAXIMUM RATINGS

| | |
|---|------------------------|
| Supply Voltage, V_{CC} | 8 V |
| Magnetic Flux Density, B | Unlimited |
| Operating Temperature Range, T_A | -20°C to +85°C |
| Storage Temperature Range, T_S | -65°C to +150°C |

The UGN3503LT, UGN3503U, and UGN3503UA Hall-effect sensors accurately track extremely small changes in magnetic flux density—changes generally too small to operate Hall-effect switches.

As motion detectors, gear tooth sensors, and proximity detectors, they are magnetically driven mirrors of mechanical events. As sensitive monitors of electromagnets, they can effectively measure a system's performance with negligible system loading while providing isolation from contaminated and electrically noisy environments.

Each Hall-effect integrated circuit includes a Hall sensing element, linear amplifier, and emitter-follower output stage. Problems associated with handling tiny analog signals are minimized by having the Hall cell and amplifier on a single chip.

Three package styles provide a magnetically optimized package for most applications. Package suffix 'LT' is a miniature SOT-89/TO-243AA transistor package for surface-mount applications; suffix 'U' is a miniature three-lead plastic SIP, while 'UA' is a three-lead ultra-mini-SIP. All devices are rated for continuous operation over the temperature range of -20°C to +85°C.

FEATURES

- Extremely Sensitive
- Flat Response to 23 kHz
- Low-Noise Output
- 4.5 V to 6 V Operation
- Magnetically Optimized Package

Always order by complete part number, e.g., **UGN3503UA**.

3503
RATIOMETRIC,
LINEAR
HALL-EFFECT SENSORS

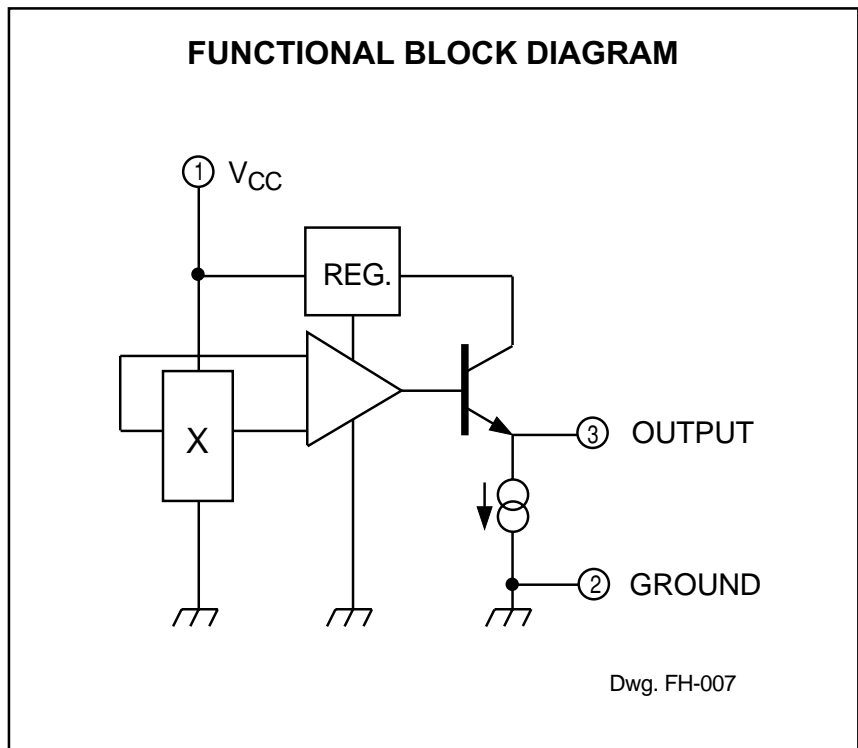

ELECTRICAL CHARACTERISTICS at $T_A = +25^\circ\text{C}$, $V_{CC} = 5\text{ V}$

| Characteristic | Symbol | Test Conditions | Limits | | | |
|--------------------------|------------------|---------------------------------------|--------|------|------|---------------|
| | | | Min. | Typ. | Max. | Units |
| Operating Voltage | V_{CC} | | 4.5 | — | 6.0 | V |
| Supply Current | I_{CC} | | — | 9.0 | 13 | mA |
| Quiescent Output Voltage | V_{OUT} | $B = 0\text{ G}$ | 2.25 | 2.50 | 2.75 | V |
| Sensitivity | ΔV_{OUT} | $B = 0\text{ G to } \pm 900\text{ G}$ | 0.75 | 1.30 | 1.75 | mV/G |
| Bandwidth (-3 dB) | BW | | — | 23 | — | kHz |
| Broadband Output Noise | V_{out} | $BW = 10\text{ Hz to } 10\text{ kHz}$ | — | 90 | — | μV |
| Output Resistance | R_{OUT} | | — | 50 | 220 | Ω |

All output-voltage measurements are made with a voltmeter having an input impedance of at least 10 k Ω .

Magnetic flux density is measured at most sensitive area of device located 0.0165" (0.42 mm) below the branded face of the 'U' package; 0.0195" (0.50 mm) below the branded face of the 'UA' package; and 0.0305" (0.775 mm) below the branded face of the 'LT' package.

3503 RATIOMETRIC, LINEAR HALL-EFFECT SENSORS

OUTPUT VOLTAGE AS A FUNCTION OF TEMPERATURE

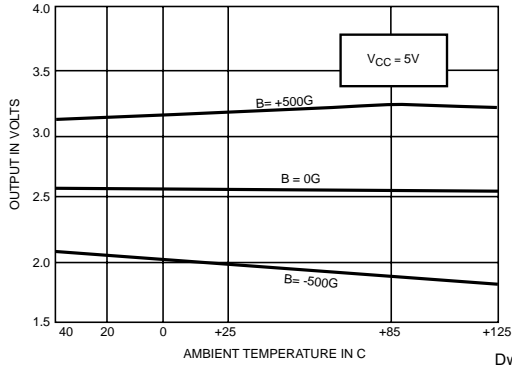

Dwg. A-12,573

OUTPUT NOISE AS A FUNCTION OF FREQUENCY

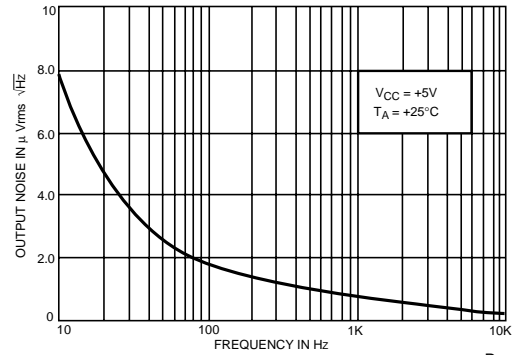

Dwg. A-12,505

SUPPLY CURRENT AS A FUNCTION OF SUPPLY VOLTAGE

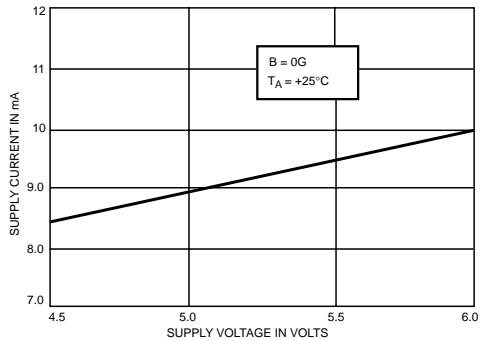

Dwg. A-12,506

DEVICE SENSITIVITY AS A FUNCTION OF SUPPLY VOLTAGE

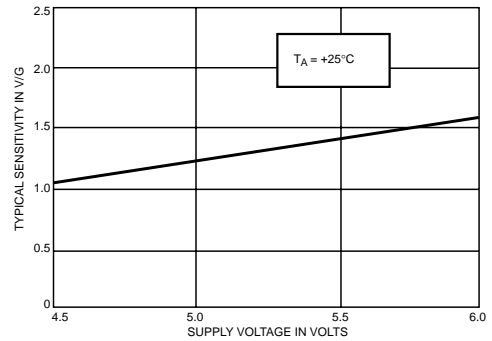

Dwg. A-12,507

OUTPUT NULL VOLTAGE AS A FUNCTION OF SUPPLY VOLTAGE

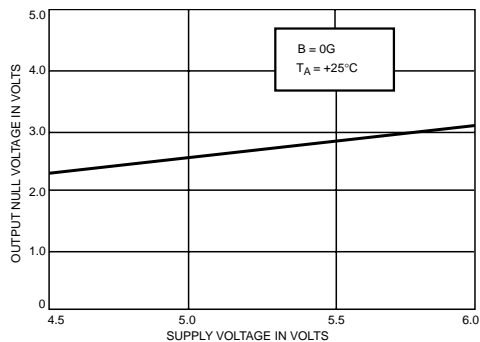

Dwg. A-12,508

LINEARITY AND SYMMETRY AS A FUNCTION OF SUPPLY VOLTAGE

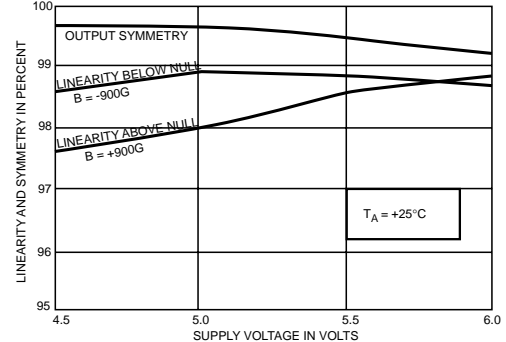

Dwg. A-12,509

3503 RATIOMETRIC, LINEAR HALL-EFFECT SENSORS

NOTCH SENSOR

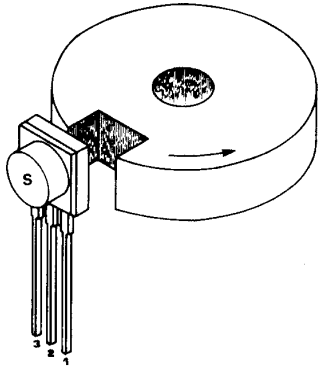

Dwg. A-12,574

GEAR TOOTH SENSOR

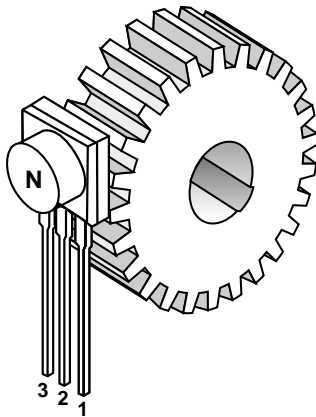

Dwg. A-12,512

CURRENT MONITOR

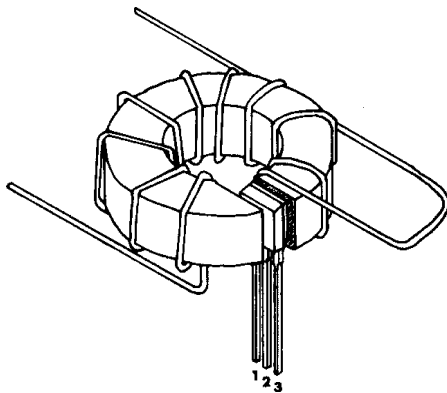

Dwg. A-12,513

OPERATION

The output null voltage ($B = 0$ G) is nominally one-half the supply voltage. A south magnetic pole, presented to the branded face of the Hall-effect sensor will drive the output higher than the null voltage level. A north magnetic pole will drive the output below the null level.

In operation, instantaneous and proportional output-voltage levels are dependent on magnetic flux density at the most sensitive area of the device. Greatest sensitivity is obtained with a supply voltage of 6 V, but at the cost of increased supply current and a slight loss of output symmetry. The sensor's output is usually capacitively coupled to an amplifier that boosts the output above the millivolt level.

In two applications shown, a permanent bias magnet is attached with epoxy glue to the back of the epoxy package. The presence of ferrous material at the face of the package acts as a flux concentrator.

The south pole of a magnet is attached to the back of the package if the Hall-effect IC is to sense the presence of ferrous material. The north pole of a magnet is attached to the back surface if the integrated circuit is to sense the absence of ferrous material.

Calibrated linear Hall devices, which can be used to determine the actual flux density presented to the sensor in a particular application, are available.

SENSOR LOCATIONS

SUFFIX "U"

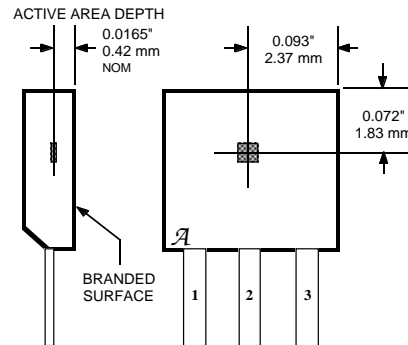

Dwg. MH-002-5D

SUFFIX "LT"

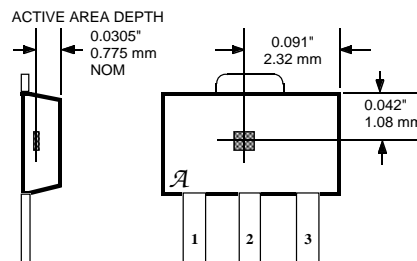

Dwg. MH-008-9A

SUFFIX "UA"

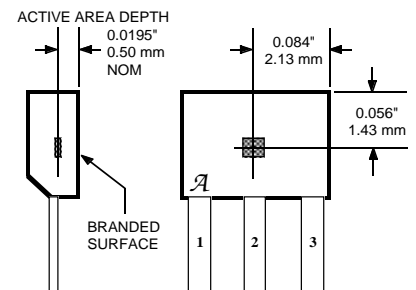

Dwg. MH-011-3D

3503 RATIOMETRIC, LINEAR HALL-EFFECT SENSORS

UGN3503LT (SOT89/TO-243AA)

Dimensions in Inches
(for reference only)

Dimensions in Millimeters
(controlling dimensions)

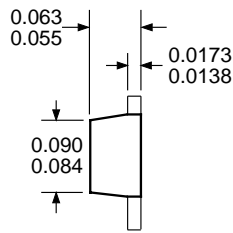
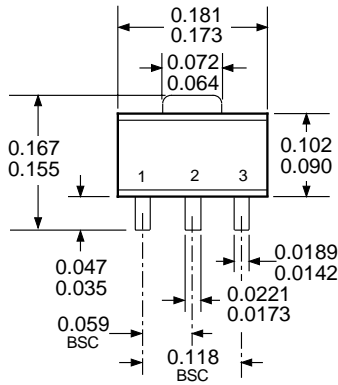

Dwg. MA-009-3A in

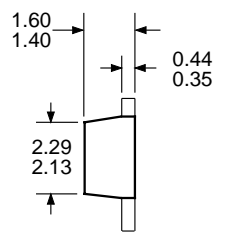
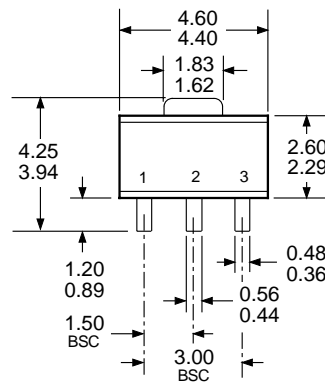

Dwg. MA-009-3A mm

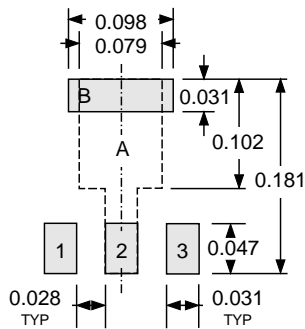

Pads 1, 2, 3, and A — Standard SOT89 Layout
 Pads 1, 2, 3, and B — Low-Stress Version
 Pads 1, 2, and 3 only — Lowest Stress, But Not Self Aligning

Dwg. MA-012-3 in

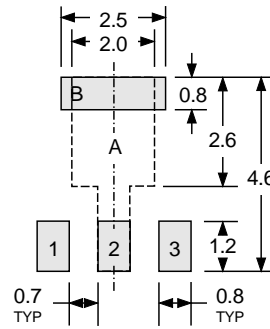

Pads 1, 2, 3, and A — Standard SOT89 Layout
 Pads 1, 2, 3, and B — Low-Stress Version
 Pads 1, 2, and 3 only — Lowest Stress, But Not Self Aligning

Dwg. MA-012-3 mm

- NOTES:
1. Exact body and lead configuration at vendor's option within limits shown.
 2. Supplied in bulk pack (500 pieces per bag) or add "TR" to part number for tape and reel.
 3. Only low-temperature ($\leq 240^{\circ}\text{C}$) reflow-soldering techniques are recommended for SOT89 devices.

3503
RATIOMETRIC,
LINEAR
HALL-EFFECT SENSORS

UGN3503U

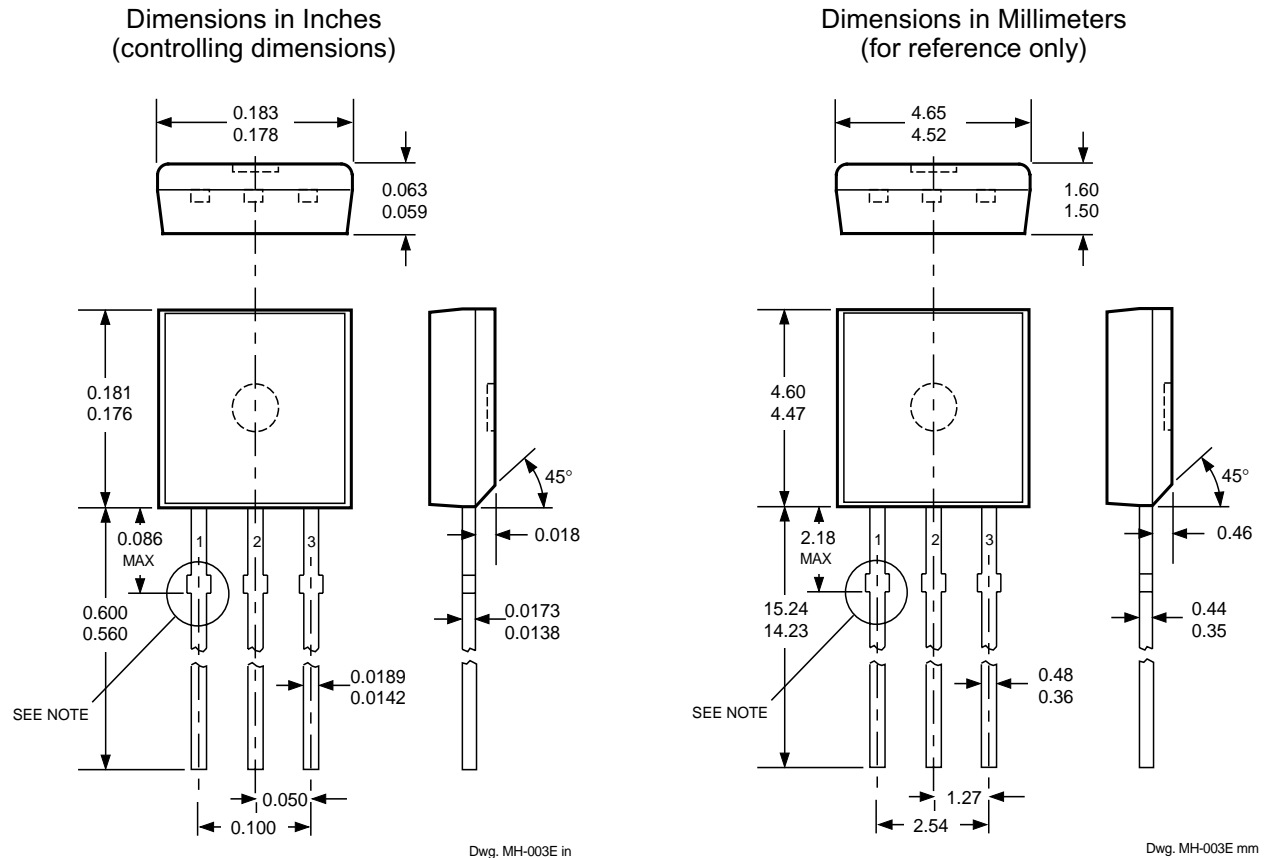

**Devices in the 'U' package are
 NOT RECOMMENDED FOR NEW DESIGN**

- NOTES:
1. Tolerances on package height and width represent allowable mold offsets. Dimensions given are measured at the widest point (parting line).
 2. Exact body and lead configuration at vendor's option within limits shown.
 3. Height does not include mold gate flash.
 4. Recommended minimum PWB hole diameter to clear transition area is 0.035" (0.89 mm).
 5. Minimum lead length was 0.500" (12.70 mm). If existing product to the original specifications is not acceptable, contact sales office before ordering.

3503 RATIOMETRIC, LINEAR HALL-EFFECT SENSORS

UGN3503UA

Dimensions in Inches
(controlling dimensions)

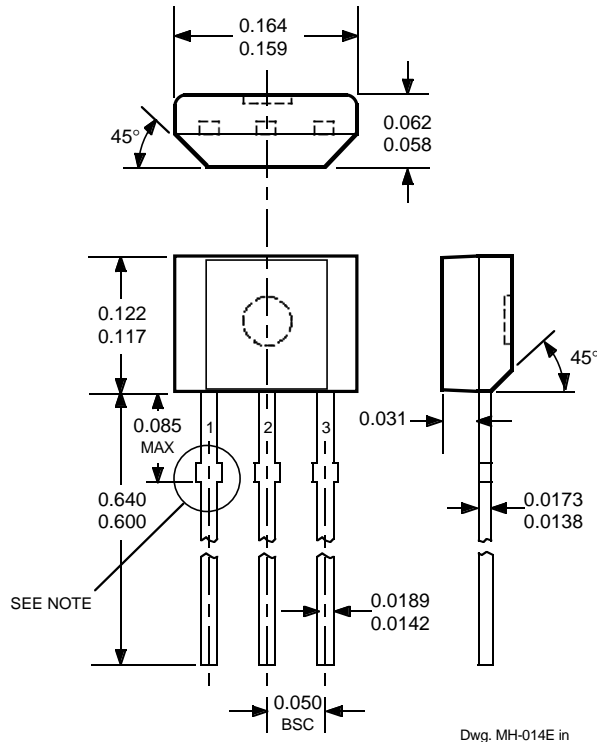

Dimensions in Millimeters
(for reference only)

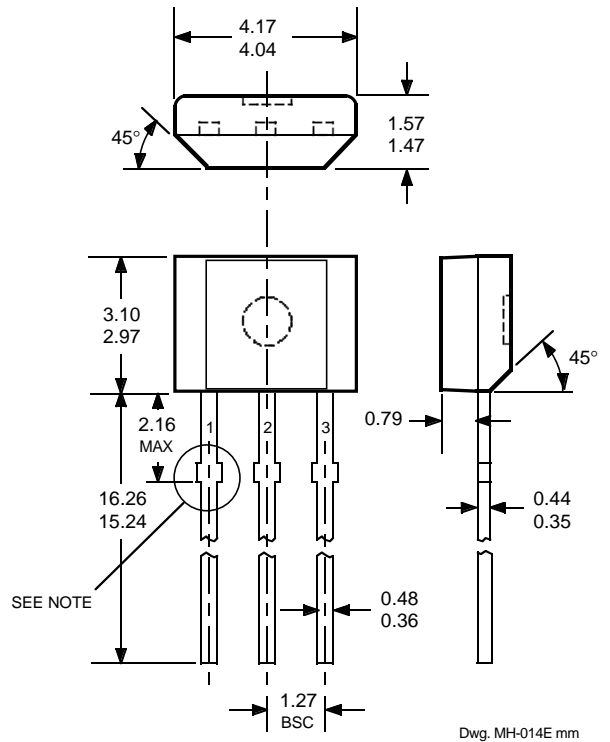

- NOTES: 1. Tolerances on package height and width represent allowable mold offsets. Dimensions given are measured at the widest point (parting line).
2. Exact body and lead configuration at vendor's option within limits shown.
3. Height does not include mold gate flash.
4. Recommended minimum PWB hole diameter to clear transition area is 0.035" (0.89 mm).
5. Where no tolerance is specified, dimension is nominal.
6. Supplied in bulk pack (500 pieces per bag).

Radial Lead Form (order UGN3503UA-LC)

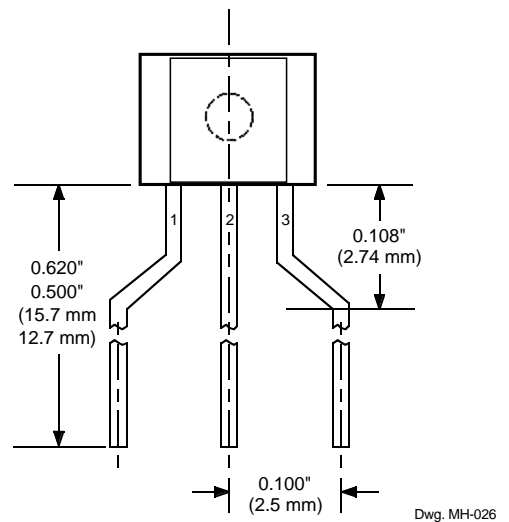

NOTE: Lead-form dimensions are the nominals produced on the forming equipment. No dimensional tolerance is implied or guaranteed for bulk packaging (500 pieces per bag).