

COMPLEMENTARY SILICON POWER TRANSISTORS

- STMicroelectronics PREFERRED SALESTYPES
- COMPLEMENTARY PNP - NPN DEVICES

DESCRIPTION

The TIP29A and TIP29C are silicon Epitaxial-Base NPN power transistors mounted in Jedec TO-220 plastic package. They are intended for use in medium power linear and switching applications.

The complementary PNP types are TIP30A and TIP30C respectively.

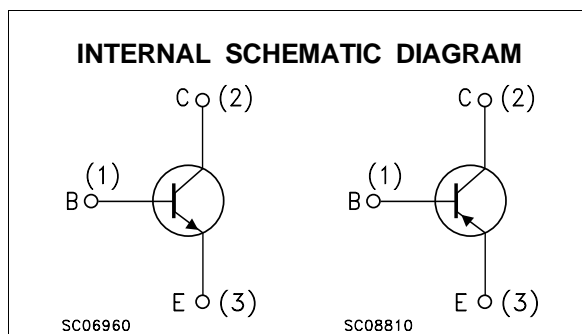
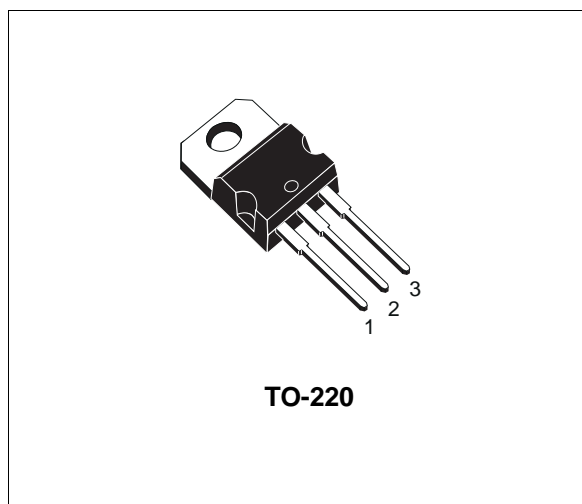

ABSOLUTE MAXIMUM RATINGS

Symbol	Parameter	Value		Unit	
		NPN	TIP29A		TIP29C
		PNP	TIP30A		TIP30C
V_{CBO}	Collector-Base Voltage ($I_E = 0$)		60	100	V
V_{CEO}	Collector-Emitter Voltage ($I_B = 0$)		60	100	V
V_{EBO}	Emitter-Base Voltage ($I_C = 0$)		5		V
I_C	Collector Current		1		A
I_{CM}	Collector Peak Current		3		A
I_B	Base Current		0.4		A
P_{tot}	Total Dissipation at $T_{case} \leq 25\text{ }^\circ\text{C}$ $T_{amb} \leq 25\text{ }^\circ\text{C}$		30		W
			2		W
T_{stg}	Storage Temperature		-65 to 150		$^\circ\text{C}$
T_j	Max. Operating Junction Temperature		150		$^\circ\text{C}$

For PNP types voltage and current values are negative.

TIP29A / TIP29C / TIP30A / TIP30C

THERMAL DATA

R _{thj-case}	Thermal Resistance Junction-case	Max	4.17	°C/W
R _{thj-amb}	Thermal Resistance Junction-ambient	Max	62.5	°C/W

ELECTRICAL CHARACTERISTICS (T_{case} = 25 °C unless otherwise specified)

Symbol	Parameter	Test Conditions		Min.	Typ.	Max.	Unit
I _{CEO}	Collector Cut-off Current (I _B = 0)	for TIP29A/30A for TIP29C/30C	V _{CE} = 30 V V _{CE} = 60 V			0.3 0.3	mA mA
I _{CES}	Collector Cut-off Current (V _{BE} = 0)	for TIP29A/30A for TIP29C/30C	V _{CE} = 60 V _{CE} = 100 V			0.2 0.2	mA mA
I _{EBO}	Emitter Cut-off Current (I _C = 0)	V _{EB} = 5 V				1	mA
V _{CEO(sus)} *	Collector-Emitter Sustaining Voltage (I _B = 0)	I _C = 30 mA for TIP29A/30A for TIP29C/30C		60 100			V V
V _{CE(sat)} *	Collector-Emitter Saturation Voltage	I _C = 1 A	I _B = 125 mA			0.7	V
V _{BE(on)} *	Base-Emitter Voltage	I _C = 1 A	V _{CE} = 4 V			1.3	V
h _{FE} *	DC Current Gain	I _C = 0.2 A I _C = 1 A	V _{CE} = 4 V V _{CE} = 4 V	40 15		75	
h _{fe}	Small Signal Current Gain	I _C = 0.2 A I _C = 0.2 A	V _{CE} = 10 V V _{CE} = 10 V	f = 1 KHz f = 1 MHz	20 3		

* Pulsed: Pulse duration = 300 μs, duty cycle ≤ 2 %
For PNP types voltage and current values are negative.

TO-220 MECHANICAL DATA

DIM.	mm			inch		
	MIN.	TYP.	MAX.	MIN.	TYP.	MAX.
A	4.40		4.60	0.173		0.181
C	1.23		1.32	0.048		0.051
D	2.40		2.72	0.094		0.107
D1		1.27			0.050	
E	0.49		0.70	0.019		0.027
F	0.61		0.88	0.024		0.034
F1	1.14		1.70	0.044		0.067
F2	1.14		1.70	0.044		0.067
G	4.95		5.15	0.194		0.203
G1	2.4		2.7	0.094		0.106
H2	10.0		10.40	0.393		0.409
L2		16.4			0.645	
L4	13.0		14.0	0.511		0.551
L5	2.65		2.95	0.104		0.116
L6	15.25		15.75	0.600		0.620
L7	6.2		6.6	0.244		0.260
L9	3.5		3.93	0.137		0.154
DIA.	3.75		3.85	0.147		0.151

