

CD4069, CD4069-SMD Inverter Circuits

General Description

The CD4069UB consists of six inverter circuits and is manufactured using complementary MOS (CMOS) to achieve wide power supply operating range, low power consumption, high noise immunity, and symmetric controlled rise and fall times.

This device is intended for all general purpose inverter applications where the special characteristics of the MM74C901, MM74C907, and CD4049A Hex Inverter/Buffers are not required. In those applications requiring larger noise immunity the MM74C14 or MM74C914 Hex Schmitt Trigger is suggested.

All inputs are protected from damage due to static discharge by diode clamps to V_{DD} and V_{SS} .

Features

- Wide supply voltage range: 3.0V to 15V
- High noise immunity: $0.45 V_{DD}$ typ.
- Low power TTL compatibility: Fan out of 2 driving 74L or 1 driving 74LS
- Equivalent to MM74C04

Ordering Code:

Order Number	Package Number	Package Description
CD4069UBCM	M14A	14-Lead Small Outline Integrated Circuit (SOIC), JEDEC MS-012, 0.150" Narrow
CD4069UBCSJ	M14D	14-Lead Small Outline Package (SOP), EIAJ TYPE II, 5.3mm Wide
CD4069UBCN	N14A	14-Lead Plastic Dual-In-Line Package (PDIP), JEDEC MS-001, 0.300" Wide

Device also available in Tape and Reel. Specify by appending suffix "X" to the ordering code.

Connection Diagram

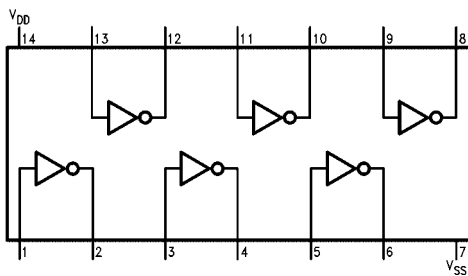

Schematic Diagram

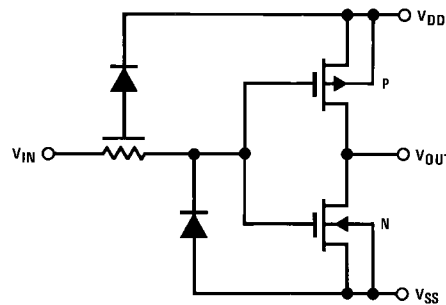

Absolute Maximum Ratings (Note 1)

(Note 2)

DC Supply Voltage (V_{DD})	-0.5V to +18 V_{DC}
Input Voltage (V_{IN})	-0.5V to V_{DD} + 0.5 V_{DC}
Storage Temperature Range (T_S)	-65°C to +150°C
Power Dissipation (P_D)	
Dual-In-Line	700 mW
Small Outline	500 mW
Lead Temperature (T_L)	
(Soldering, 10 seconds)	260°C

Recommended Operating Conditions (Note 2)

DC Supply Voltage (V_{DD})	3V to 15 V_{DC}
Input Voltage (V_{IN})	0V to V_{DD} V_{DC}
Operating Temperature Range (T_A)	-55°C to +125°C

Note 1: "Absolute Maximum Ratings" are those values beyond which the safety of the device cannot be guaranteed. They are not meant to imply that the devices should be operated at these limits. The table of "Recommended Operating Conditions" and Electrical Characteristics table provide conditions for actual device operation.

Note 2: $V_{SS} = 0V$ unless otherwise specified.

DC Electrical Characteristics (Note 3)

Symbol	Parameter	Conditions	-55°C		+25°C			+125°C		Units
			Min	Max	Min	Typ	Max	Min	Max	
I_{DD}	Quiescent Device Current	$V_{DD} = 5V$, $V_{IN} = V_{DD}$ or V_{SS} $V_{DD} = 10V$, $V_{IN} = V_{DD}$ or V_{SS} $V_{DD} = 15V$, $V_{IN} = V_{DD}$ or V_{SS}		0.25			0.25		7.5	μA
				0.5			0.5	15		
				1.0			1.0	30		
V_{OL}	LOW Level Output Voltage	$ I_O < 1 \mu A$ $V_{DD} = 5V$ $V_{DD} = 10V$ $V_{DD} = 15V$		0.05	0	0.05		0.05	0.05	V
				0.05	0	0.05		0.05	0.05	
				0.05	0	0.05		0.05	0.05	
V_{OH}	HIGH Level Output Voltage	$ I_O < 1 \mu A$ $V_{DD} = 5V$ $V_{DD} = 10V$ $V_{DD} = 15V$	4.95		4.95	5		4.95		V
			9.95		9.95	10		9.95		
			14.95		14.95	15		14.95		
V_{IL}	LOW Level Input Voltage	$ I_O < 1 \mu A$ $V_{DD} = 5V, V_O = 4.5V$ $V_{DD} = 10V, V_O = 9V$ $V_{DD} = 15V, V_O = 13.5V$		1.0			1.0		1.0	V
				2.0			2.0		2.0	
				3.0			3.0		3.0	
V_{IH}	HIGH Level Input Voltage	$ I_O < 1 \mu A$ $V_{DD} = 5V, V_O = 0.5V$ $V_{DD} = 10V, V_O = 1V$ $V_{DD} = 15V, V_O = 1.5V$	4.0		4.0			4.0		V
			8.0		8.0			8.0		
			12.0		12.0			12.0		
I_{OL}	LOW Level Output Current (Note 4)	$V_{DD} = 5V, V_O = 0.4V$ $V_{DD} = 10V, V_O = 0.5V$ $V_{DD} = 15V, V_O = 1.5V$	0.64		0.51	0.88		0.36		mA
			1.6		1.3	2.25		0.9		
			4.2		3.4	8.8		2.4		
I_{OH}	HIGH Level Output Current (Note 4)	$V_{DD} = 5V, V_O = 4.6V$ $V_{DD} = 10V, V_O = 9.5V$ $V_{DD} = 15V, V_O = 13.5V$	-0.64		-0.51	-0.88		-0.36		mA
			-1.6		-1.3	-2.25		-0.9		
			-4.2		-3.4	-8.8		-2.4		
I_{IN}	Input Current	$V_{DD} = 15V, V_{IN} = 0V$ $V_{DD} = 15V, V_{IN} = 15V$		-0.1		-10^{-5}	-0.1		-1.0	μA
				0.1		10^{-5}	0.1		1.0	

Note 3: $V_{SS} = 0V$ unless otherwise specified.

Note 4: I_{OH} and I_{OL} are tested one output at a time.

AC Electrical Characteristics (Note 5)						
T _A = 25°C, C _L = 50 pF, R _L = 200 kΩ, t _r and t _f ≤ 20 ns, unless otherwise specified						
Symbol	Parameter	Conditions	Min	Typ	Max	Units
t _{PHL} or t _{PLH}	Propagation Delay Time from Input to Output	V _{DD} = 5V V _{DD} = 10V V _{DD} = 15V		50 30 25	90 60 50	ns
t _{THL} or t _{TLH}	Transition Time	V _{DD} = 5V V _{DD} = 10V V _{DD} = 15V		80 50 40	150 100 80	ns
C _{IN}	Average Input Capacitance	Any Gate		6	15	pF
C _{PD}	Power Dissipation Capacitance	Any Gate (Note 6)		12		pF

Note 5: AC Parameters are guaranteed by DC correlated testing.

Note 6: C_{PD} determines the no load AC power consumption of any CMOS device. For complete explanation, see Family Characteristics application note—AN-90.

AC Test Circuits and Switching Time Waveforms

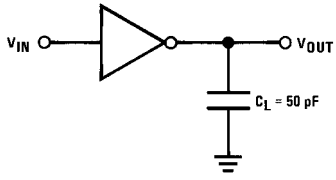

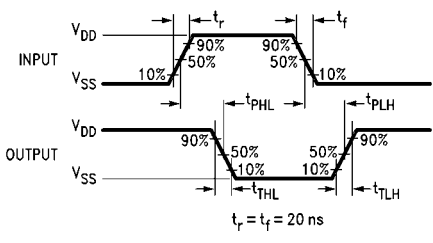

Typical Performance Characteristics

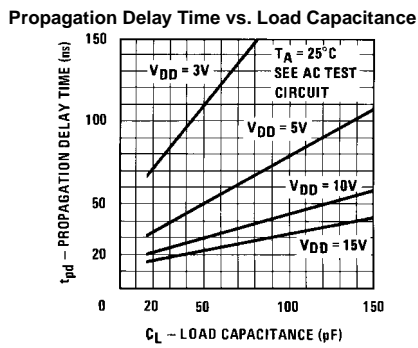
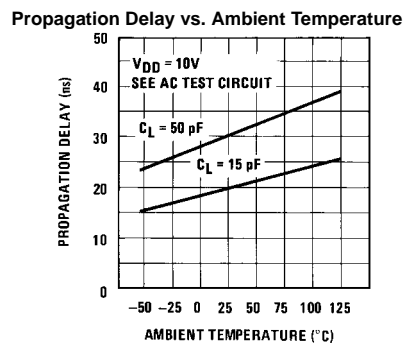
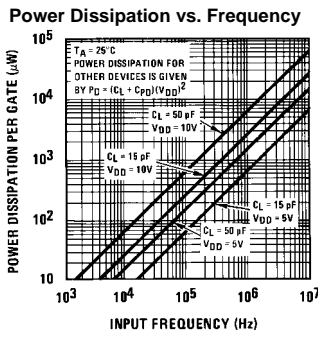
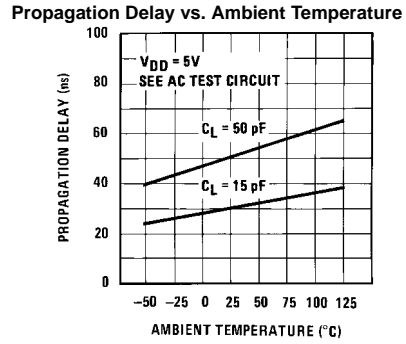
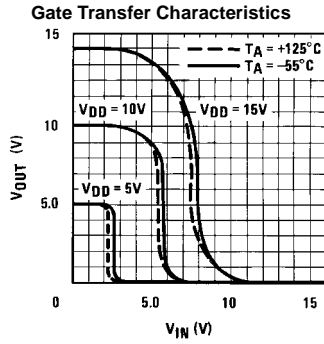

Physical Dimensions inches (millimeters) unless otherwise noted

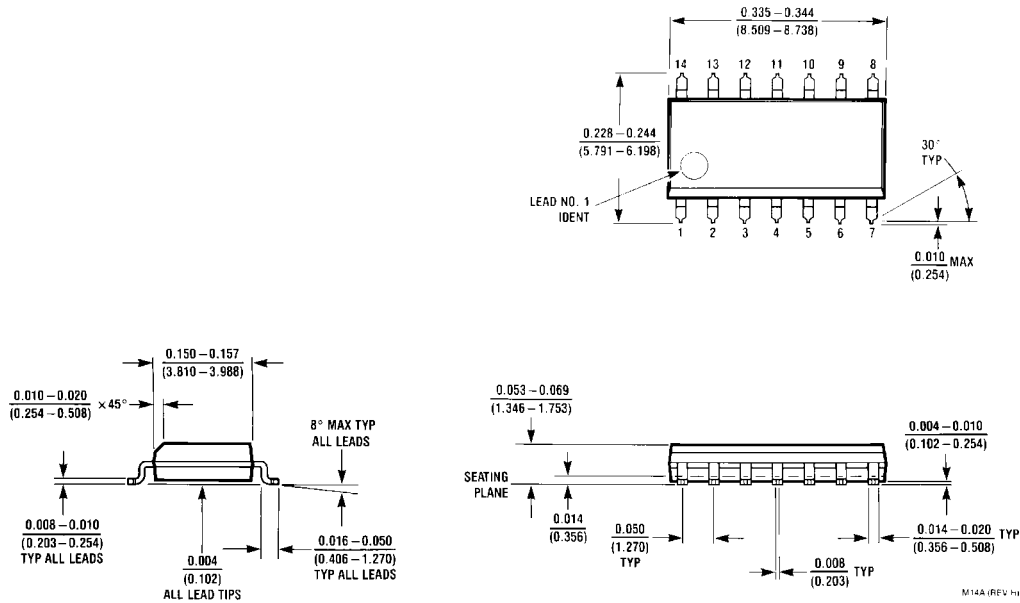

**14-Lead Small Outline Integrated Circuit (SOIC), JEDEC MS-012, 0.150" Narrow
Package Number M14A**

CD4069UBC

Physical Dimensions inches (millimeters) unless otherwise noted (Continued)

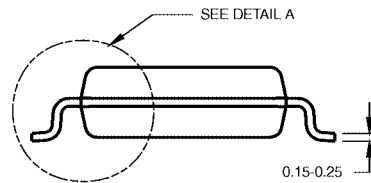
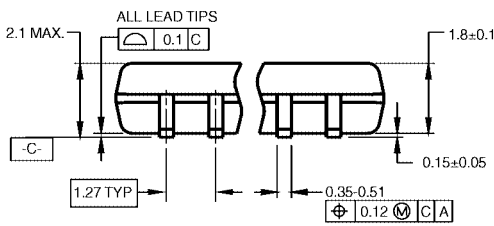
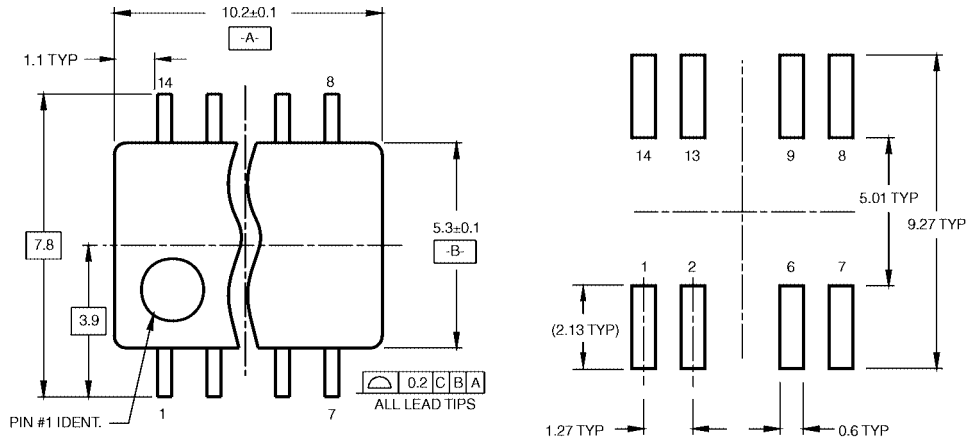

DIMENSIONS ARE IN MILLIMETERS

- NOTES:
 A. CONFORMS TO EIAJ EDR-7320 REGISTRATION, ESTABLISHED IN DECEMBER, 1998.
 B. DIMENSIONS ARE IN MILLIMETERS.
 C. DIMENSIONS ARE EXCLUSIVE OF BURRS, MOLD FLASH, AND TIE BAR EXTRUSIONS.

M14DRevB1

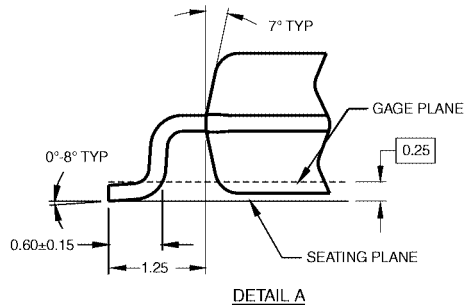

**14-Lead Small Outline Package (SOP), EIAJ TYPE II, 5.3mm Wide
 Package Number M14D**

Physical Dimensions inches (millimeters) unless otherwise noted (Continued)

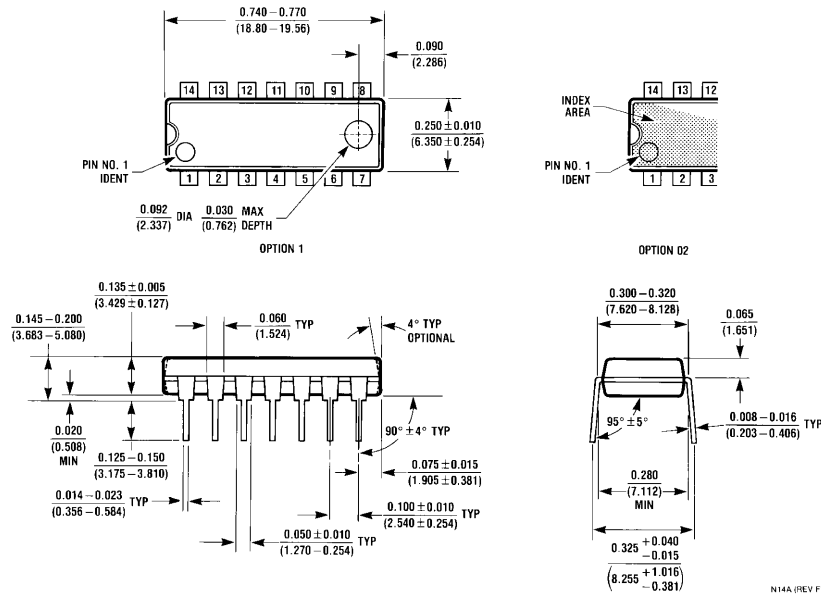

14-Lead Plastic Dual-In-Line Package (PDIP), JEDEC MS-001, 0.300" Wide Package Number N14A

N14A (REV F)