

---

# 82C55

---

## CMOS PROGRAMMABLE PERIPHERAL INTERFACE

---

### GENERAL DESCRIPTION

The MSM82C55A-2 is a programmable universal I/O interface device which operates as high speed and on low power consumption due to 3 $\mu$  silicon gate CMOS technology. It is the best fit as an I/O port in a system which employs the 8-bit parallel processing MSM80C85AH CPU. This device has 24-bit I/O pins equivalent to three 8-bit I/O ports and all inputs/outputs are TTL interface compatible.

### FEATURES

- High speed and low power consumption due to 3 $\mu$  silicon gate CMOS technology
- 3 V to 6 V single power supply
- Full static operation
- Programmable 24-bit I/O ports
- Bidirectional bus operation (Port A)
- Bit set/reset function (Port C)
- TTL compatible
- Compatible with 8255A-5
- 40-pin Plastic DIP (DIP40-P-600-2.54): (Product name: MSM82C55A-2RS)
- 44-pin Plastic QFJ (QFJ44-P-S650-1.27): (Product name: MSM82C55A-2VJS)
- 44-pin Plastic QFP (QFP44-P-910-0.80-2K): (Product name: MSM82C55A-2GS-2K)

CIRCUIT CONFIGURATION

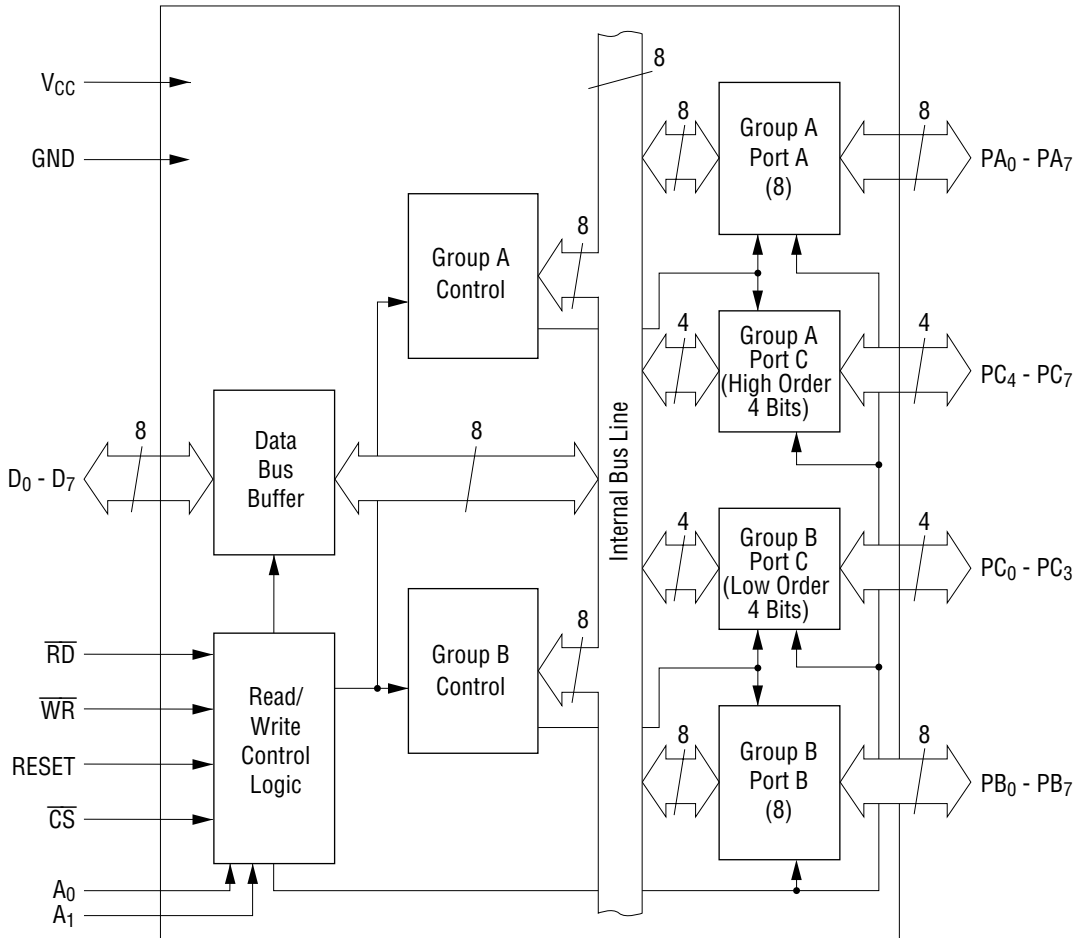

**PIN CONFIGURATION (TOP VIEW)**

**40 pin Plastic DIP**

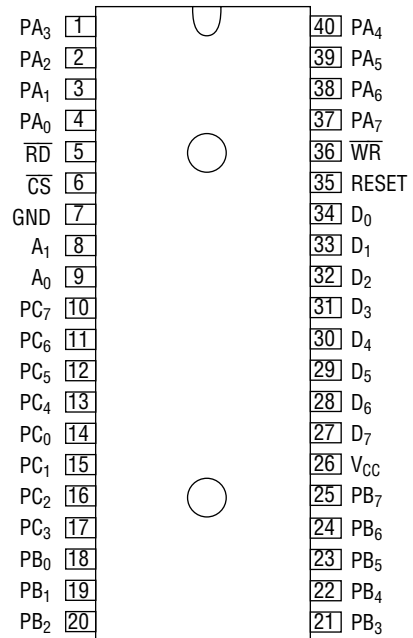

**44 pin Plastic QFP**

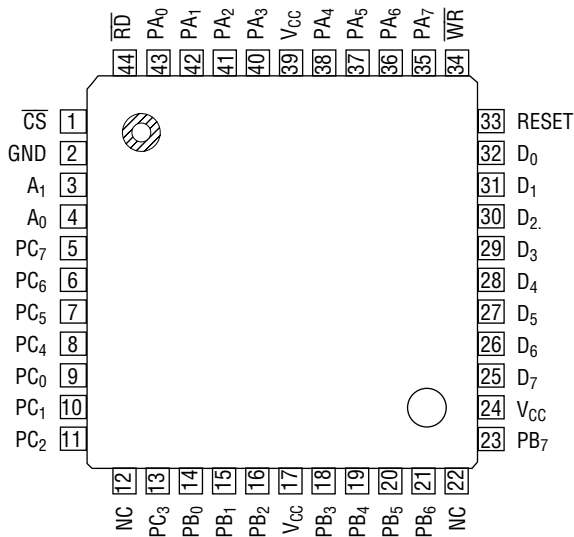

**44 pin Plastic QFJ**

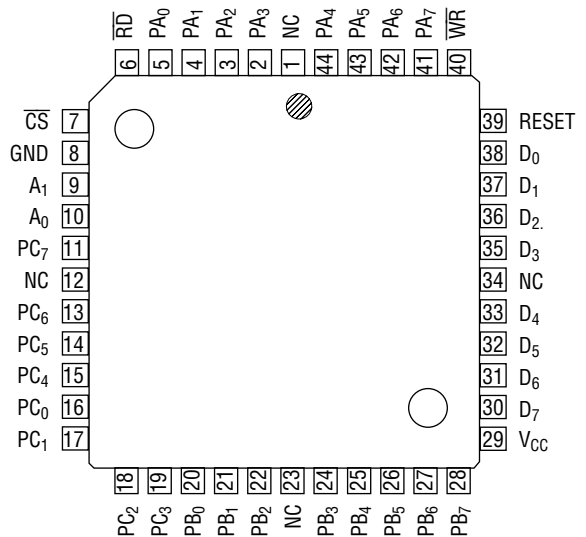

**ABSOLUTE MAXIMUM RATINGS**

Parameter	Symbol	Conditions	Rating			Unit
			MSM82C55A-2RS	MSM82C55A-2GS	MSM82C55A-2vJS	
Supply Voltage	$V_{CC}$	$T_a = 25^{\circ}\text{C}$	-0.5 to +7			V
Input Voltage	$V_{IN}$	with respect to GND	-0.5 to $V_{CC} + 0.5$			V
Output Voltage	$V_{OUT}$		-0.5 to $V_{CC} + 0.5$			V
Storage Temperature	$T_{STG}$	—	-55 to +150			$^{\circ}\text{C}$
Power Dissipation	$P_D$	$T_a = 25^{\circ}\text{C}$	1.0	0.7	1.0	W

**OPERATING RANGE**

Parameter	Symbol	Range	Unit
Supply Voltage	$V_{CC}$	3 to 6	V
Operating Temperature	$T_{op}$	-40 to 85	$^{\circ}\text{C}$

**RECOMMENDED OPERATING RANGE**

Parameter	Symbol	Min.	Typ.	Max.	Unit
Supply Voltage	$V_{CC}$	4.5	5	5.5	V
Operating Temperature	$T_{op}$	-40	+25	+85	$^{\circ}\text{C}$
"L" Input Voltage	$V_{IL}$	-0.3	—	+0.8	V
"H" Input Voltage	$V_{IH}$	2.2	—	$V_{CC} + 0.3$	V

**DC CHARACTERISTICS**

Parameter	Symbol	Conditions	MSM82C55A-2			Unit
			Min.	Typ.	Max.	
"L" Output Voltage	$V_{OL}$	$I_{OL} = 2.5 \text{ mA}$	—	—	0.4	V
"H" Output Voltage	$V_{OH}$	$I_{OH} = -40 \mu\text{A}$	4.2	—	—	V
		$I_{OH} = -2.5 \text{ mA}$	3.7	—	—	V
Input Leak Current	$I_{LI}$	$0 \leq V_{IN} \leq V_{CC}$	-1	—	1	$\mu\text{A}$
Output Leak Current	$I_{LO}$	$0 \leq V_{OUT} \leq V_{CC}$	-10	—	10	$\mu\text{A}$
Supply Current (Standby)	$I_{CCS}$	$\overline{CS} \geq V_{CC} - 0.2 \text{ V}$ $V_{IH} \geq V_{CC} - 0.2 \text{ V}$ $V_{IL} \leq 0.2 \text{ V}$	—	0.1	10	$\mu\text{A}$
Average Supply Current (Active)	$I_{CC}$	I/O Wire Cycle 82C55A-2 ...8 MHz CPU Timing	—	—	8	mA

**AC CHARACTERISTICS**

( $V_{CC} = 4.5\text{ V to }5.5\text{ V}$ ,  $T_a = -40\text{ to }+85^\circ\text{C}$ )

Parameter	Symbol	MSM82C55A-2		Unit	Remarks
		Min.	Max.		
Setup Time of Address to the Falling Edge of $\overline{RD}$	$t_{AR}$	20	—	ns	Load 150 pF
Hold Time of Address to the Rising Edge of $\overline{RD}$	$t_{RA}$	0	—	ns	
$\overline{RD}$ Pulse Width	$t_{RR}$	100	—	ns	
Delay Time from the Falling Edge of $\overline{RD}$ to the Output of Defined Data	$t_{RD}$	—	120	ns	
Delay Time from the Rising Edge of $\overline{RD}$ to the Floating of Data Bus	$t_{DF}$	10	75	ns	
Time from the Rising Edge of $\overline{RD}$ or $\overline{WR}$ to the Next Falling Edge of $\overline{RD}$ or $\overline{WR}$	$t_{RV}$	200	—	ns	
Setup Time of Address before the Falling Edge of $\overline{WR}$	$t_{AW}$	0	—	ns	
Hold Time of Address after the Rising Edge of $\overline{WR}$	$t_{WA}$	20	—	ns	
$\overline{WR}$ Pulse Width	$t_{WW}$	150	—	ns	
Setup Time of Bus Data before the Rising Edge of $\overline{WR}$	$t_{DW}$	50	—	ns	
Hold Time of Bus Data after the Rising Edge of $\overline{WR}$	$t_{WD}$	30	—	ns	
Delay Time from the rising Edge of $\overline{WR}$ to the Output of Defined Data	$t_{WB}$	—	200	ns	
Setup Time of Port Data before the Falling Edge of $\overline{RD}$	$t_{IR}$	20	—	ns	
Hold Time of Port Data after the Rising Edge of $\overline{RD}$	$t_{HR}$	10	—	ns	
$\overline{ACK}$ Pulse Width	$t_{AK}$	100	—	ns	
$\overline{STB}$ Pulse Width	$t_{ST}$	100	—	ns	
Setup Time of Port Data before the rising Edge of $\overline{STB}$	$t_{PS}$	20	—	ns	
Hold Time of Port Bus Data after the rising Edge of $\overline{STB}$	$t_{PH}$	50	—	ns	
Delay Time from the Falling Edge of $\overline{ACK}$ to the Output of Defined Data	$t_{AD}$	—	150	ns	
Delay Time from the Rising Edge of $\overline{ACK}$ to the Floating of Port (Port A in Mode 2)	$t_{KD}$	20	250	ns	
Delay Time from the Rising Edge of $\overline{WR}$ to the Falling Edge of $\overline{OBF}$	$t_{WOB}$	—	150	ns	
Delay Time from the Falling Edge of $\overline{ACK}$ to the Rising Edge of $\overline{OBF}$	$t_{AOB}$	—	150	ns	
Delay Time from the Falling Edge of $\overline{STB}$ to the Rising Edge of $\overline{IBF}$	$t_{SIB}$	—	150	ns	
Delay Time from the Rising Edge of $\overline{RD}$ to the Falling Edge of $\overline{IBF}$	$t_{RIB}$	—	150	ns	
Delay Time from the the Falling Edge of $\overline{RD}$ to the Falling Edge of $\overline{INTR}$	$t_{RIT}$	—	200	ns	
Delay Time from the Rising Edge of $\overline{STB}$ to the Rising Edge of $\overline{INTR}$	$t_{SIT}$	—	150	ns	
Delay Time from the Rising Edge of $\overline{ACK}$ to the Rising Edge of $\overline{INTR}$	$t_{AIT}$	—	150	ns	
Delay Time from the Falling Edge of $\overline{WR}$ to the Falling Edge of $\overline{INTR}$	$t_{WIT}$	—	250	ns	

Note: Timing measured at  $V_L = 0.8\text{ V}$  and  $V_H = 2.2\text{ V}$  for both inputs and outputs.

**TIMING DIAGRAM**

**Basic Input Operation (Mode 0)**

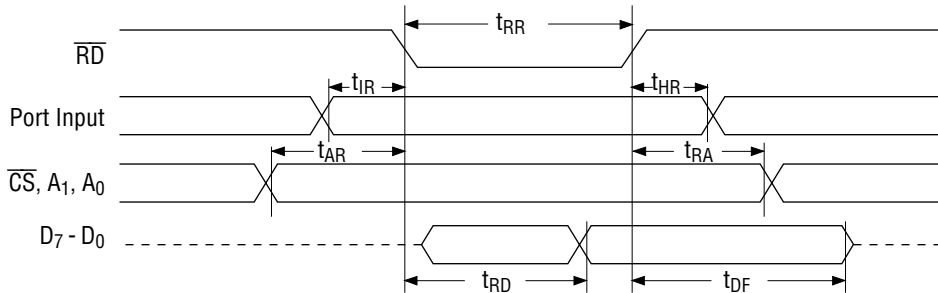

**Basic Output Operation (Mode 0)**

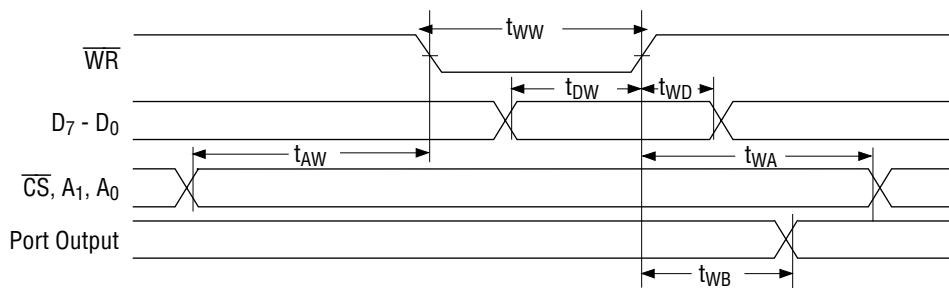

**Strobe Input Operation (Mode 1)**

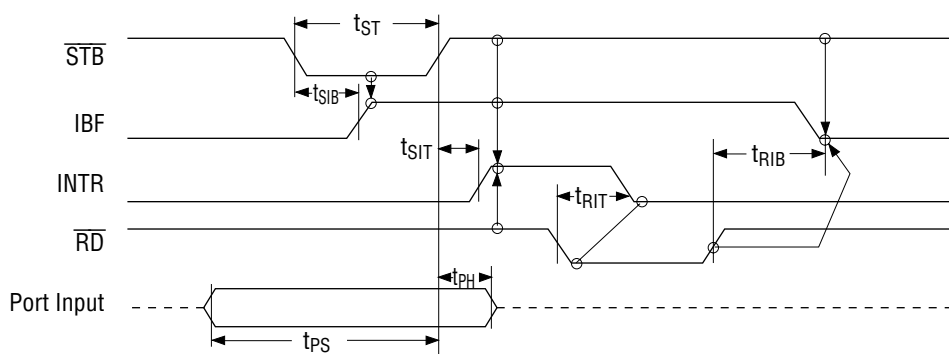

**Strobe Output Operation (Mode 1)**

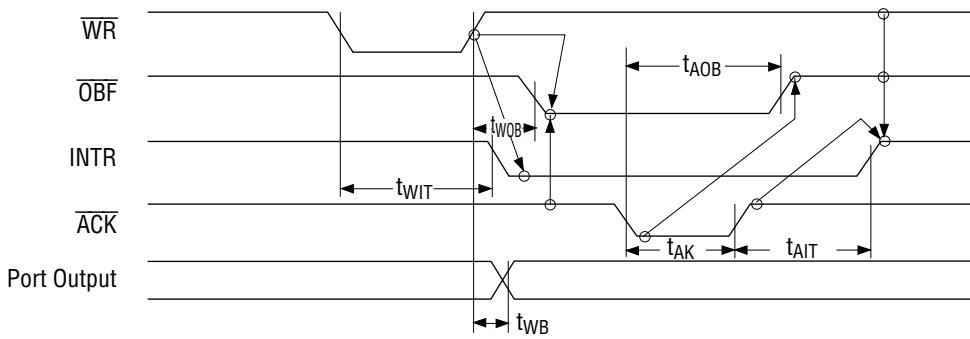

**Bidirectional Bus Operation (Mode 2)**

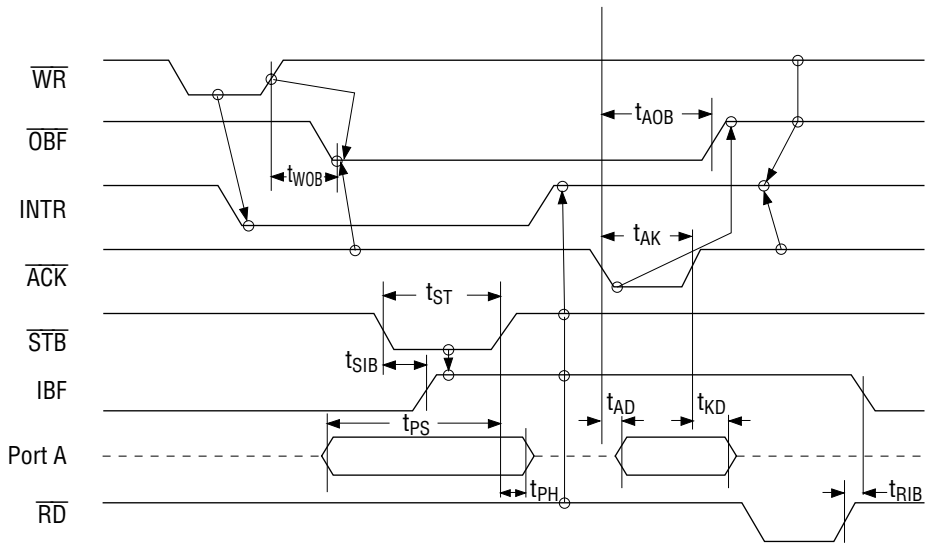

**OUTPUT CHARACTERISTICS (REFERENCE VALUE)**

**1 Output "H" Voltage ( $V_{OH}$ ) vs. Output Current ( $I_{OH}$ )**

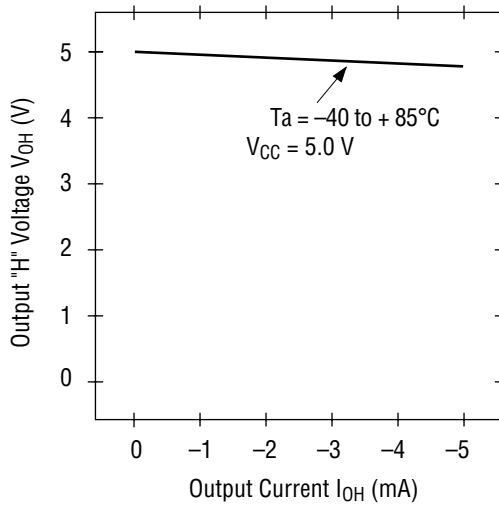

**2 Output "L" Voltage ( $V_{OL}$ ) vs. Output Current ( $I_{OL}$ )**

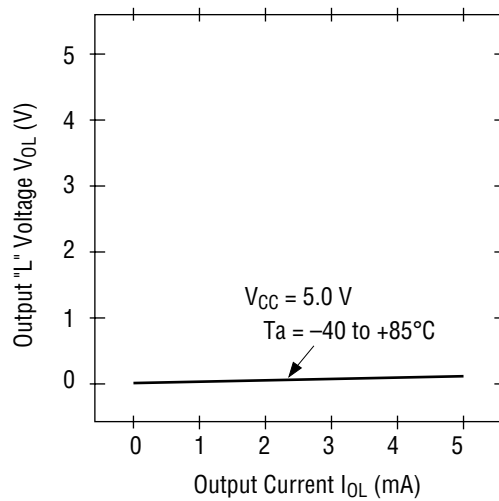

Note: The direction of flowing into the device is taken as positive for the output current.



## PIN DESCRIPTION

Pin No.	Item	Input/Output	Function
D <sub>7</sub> - D <sub>0</sub>	Bidirectional Data Bus	Input and Output	These are three-state 8-bit bidirectional buses used to write and read data upon receipt of the $\overline{WR}$ and $\overline{RD}$ signals from CPU and also used when control words and bit set/reset data are transferred from CPU to MSM82C55A-2.
RESET	Reset Input	Input	This signal is used to reset the control register and all internal registers when it is in high level. At this time, ports are all made into the input mode (high impedance status). all port latches are cleared to 0. and all ports groups are set to mode 0.
$\overline{CS}$	Chip Select Input	Input	When the $\overline{CS}$ is in low level, data transmission is enabled with CPU. When it is in high level, the data bus is made into the high impedance status where no write nor read operation is performed. Internal registers hold their previous status, however.
$\overline{RD}$	Read Input	Input	When $\overline{RD}$ is in low level, data is transferred from MSM82C55A-2 to CPU.
$\overline{WR}$	Write Input	Input	When $\overline{WR}$ is in low level, data or control words are transferred from CPU to MSM82C55A-2.
A <sub>0</sub> , A <sub>1</sub>	Port Select Input (Address)	Input	By combination of A <sub>0</sub> and A <sub>1</sub> , either one is selected from among port A, port B, port C, and control register. These pins are usually connected to low order 2 bits of the address bus.
PA <sub>7</sub> - PA <sub>0</sub>	Port A	Input and Output	These are universal 8-bit I/O ports. The direction of inputs/ outputs can be determined by writing a control word. Especially, port A can be used as a bidirectional port when it is set to mode 2.
PB <sub>7</sub> - PB <sub>0</sub>	Port B	Input and Output	These are universal 8-bit I/O ports. The direction of inputs/outputs ports can be determined by writing a control word.
PC <sub>7</sub> - PC <sub>0</sub>	Port C	Input and Output	These are universal 8-bit I/O ports. The direction of inputs/outputs can be determined by writing a control word as 2 ports with 4 bits each. When port A or port B is used in mode 1 or mode 2 (port A only), they become control pins. Especially, when port C is used as an output port, each bit can set/reset independently.
V <sub>CC</sub>	-	-	+5V power supply.
GND	-	-	GND

## BASIC FUNCTIONAL DESCRIPTION

### Group A and Group B

When setting a mode to a port having 24 bits, set it by dividing it into two groups of 12 bits each.

Group A: Port A (8 bits) and high order 4 bits of port C (PC<sub>7</sub>~PC<sub>4</sub>)

Group B: Port B (8 bits) and low order 4 bits of port C (PC<sub>3</sub>~PC<sub>0</sub>)

### Mode 0, 1, 2

There are 3 types of modes to be set by grouping as follows:

Mode 0: Basic input operation/output operation (Available for both groups A and B)

Mode 1: Strobe input operation/output operation (Available for both groups A and B)

Mode 2: Bidirectional bus operation (Available for group A only)

When used in mode 1 or mode 2, however, port C has bits to be defined as ports for control signal for operation ports (port A for group A and port B for group B) of their respective groups.

### Port A, B, C

The internal structure of 3 ports is as follows:

Port A: One 8-bit data output latch/buffer and one 8-bit data input latch

Port B: One 8-bit data input/output latch/buffer and one 8-bit data input buffer

Port C: One 8-bit data output latch/buffer and one 8-bit data input buffer (no latch for input)

### Single bit set/reset function for port C

When port C is defined as an output port, it is possible to set (to turn to high level) or reset (to turn to low level) any one of 8 bits individually without affecting other bits.

## OPERATIONAL DESCRIPTION

### Control Logic

Operations by addresses and control signals, e.g., read and write, etc. are as shown in the table below:

Operaiton	A <sub>1</sub>	A <sub>0</sub>	$\overline{CS}$	$\overline{WR}$	$\overline{RD}$	Operation
Input	0	0	0	1	0	Port A → Data Bus
	0	1	0	1	0	Port B → Data Bus
	1	0	0	1	0	Port C → Data Bus
Output	0	0	0	0	1	Data Bus → Port A
	0	1	0	0	1	Data Bus → Port B
	1	0	0	0	1	Data Bus → Port C
Control	1	1	0	0	1	Data Bus → Control Register
Others	1	1	0	1	0	Illegal Condition
	×	×	1	×	×	Data bus is in the high impedance status.

### Setting of Control Word

The control register is composed of 7-bit latch circuit and 1-bit flag as shown below.

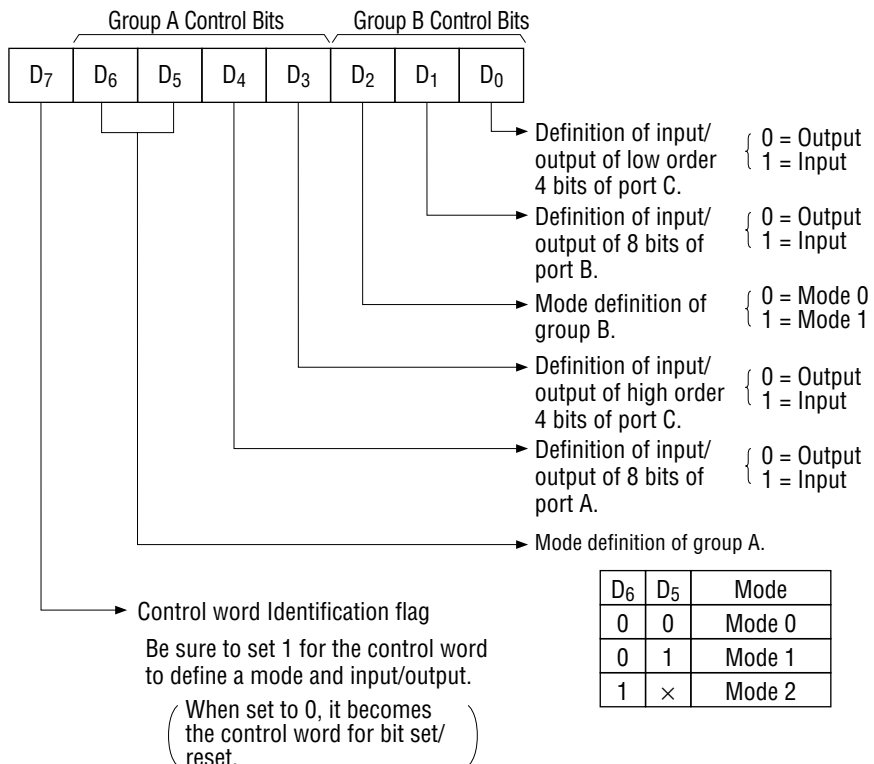

**Precaution for Mode Selection**

The output registers for ports A and C are cleared to  $\phi$  each time data is written in the command register and the mode is changed, but the port B state is undefined.

**Bit Set/Reset Function**

When port C is defined as output port, it is possible to set (set output to 1) or reset (set output to 0) any one of 8 bits without affecting other bits as shown below.

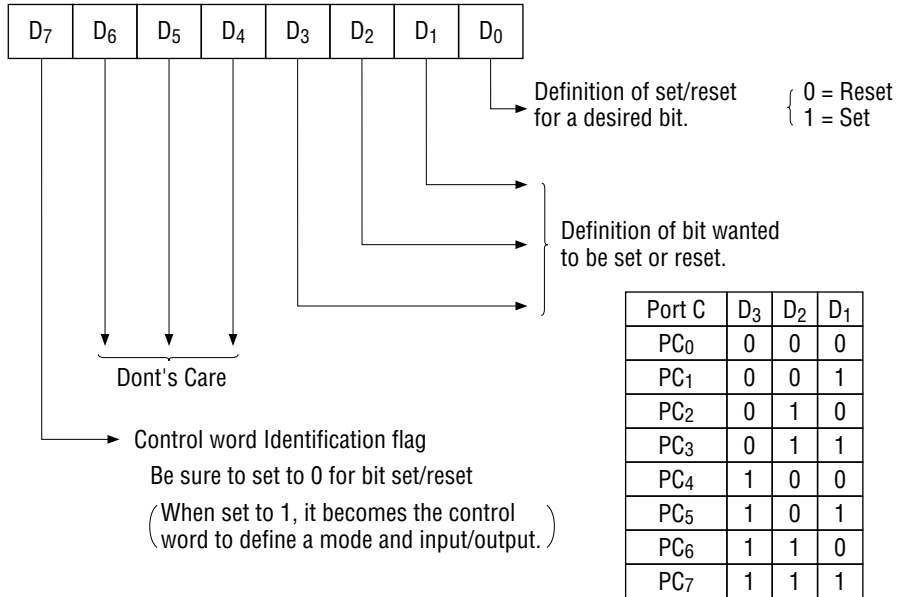

**Interrupt Control Function**

When the MSM82C55A-2 is used in mode 1 or mode 2, the interrupt signal for the CPU is provided. The interrupt request signal is output from port C. When the internal flip-flop INTE is set beforehand at this time, the desired interrupt request signal is output. When it is reset beforehand, however, the interrupt request signal is not output. The set/reset of the internal flip-flop is made by the bit set/reset operation for port C virtually.

Bit set ⇒ INTE is set ⇒ Interrupt allowed  
 Bit reset ⇒ INTE is reset ⇒ Interrupt inhibited

**Operational Description by Mode**

**1. Mode 0 (Basic input/output operation)**

Mode 0 makes the MSM82C55A-2 operate as a basic input port or output port. No control signals such as interrupt request, etc. are required in this mode. All 24 bits can be used as two-8-bit ports and two 4-bit ports. Sixteen combinations are then possible for inputs/outputs. The inputs are not latched, but the outputs are.

Type	Control Word								Group A		Group B	
	D <sub>7</sub>	D <sub>6</sub>	D <sub>5</sub>	D <sub>4</sub>	D <sub>3</sub>	D <sub>2</sub>	D <sub>1</sub>	D <sub>0</sub>	Port A	High Order 4 Bits of Port C	Port B	Low Order 4 Bits of Port C
1	1	0	0	0	0	0	0	0	Output	Output	Output	Output
2	1	0	0	0	0	0	0	1	Output	Output	Output	Input
3	1	0	0	0	0	0	1	0	Output	Output	Input	Output
4	1	0	0	0	0	0	1	1	Output	Output	Input	Input
5	1	0	0	0	1	0	0	0	Output	Input	Output	Output
6	1	0	0	0	1	0	0	1	Output	Input	Output	Input
7	1	0	0	0	1	0	1	0	Output	Input	Input	Output
8	1	0	0	0	1	0	1	1	Output	Input	Input	Input
9	1	0	0	1	0	0	0	0	Input	Output	Output	Output
10	1	0	0	1	0	0	0	1	Input	Output	Output	Input
11	1	0	0	1	0	0	1	0	Input	Output	Input	Output
12	1	0	0	1	0	0	1	1	Input	Output	Input	Input
13	1	0	0	1	1	0	0	0	Input	Input	Output	Output
14	1	0	0	1	1	0	0	1	Input	Input	Output	Input
15	1	0	0	1	1	0	1	0	Input	Input	Input	Output
16	1	0	0	1	1	0	1	1	Input	Input	Input	Input

Notes: When used in mode 0 for both groups A and B

**2. Mode 1 (Strobe input/output operation)**

In mode 1, the strobe, interrupt and other control signals are used when input/output operations are made from a specified port. This mode is available for both groups A and B. In group A at this time, port A is used as the data line and port C as the control signal. Following is a description of the input operation in mode 1.

**$\overline{STB}$  (Strobe input)**

When this signal is low level, the data output from terminal to port is fetched into the internal latch of the port. This can be made independent from the CPU, and the data is not output to the data bus until the  $\overline{RD}$  signal arrives from the CPU.

**IBF (Input buffer full flag output)**

This is the response signal for the  $\overline{STB}$ . This signal when turned to high level indicates that data is fetched into the input latch. This signal turns to high level at the falling edge of  $\overline{STB}$  and to low level at the rising edge of  $\overline{RD}$ .

**INTR (Interrupt request output)**

This is the interrupt request signal for the CPU of the data fetched into the input latch. It is indicated by high level only when the internal INTE flip-flop is set. This signal turns to high level at the rising edge of the  $\overline{STB}$  (IBF = 1 at this time) and low level at the falling edge of the  $\overline{RD}$  when the INTE is set.

INTE<sub>A</sub> of group A is set when the bit for PC<sub>4</sub> is set, while INTE<sub>B</sub> of group B is set when the bit for PC<sub>2</sub> is set.

Following is a description of the output operation of mode 1.

**$\overline{\text{OBF}}$  (Output buffer full flag output)**

This signal when turned to low level indicates that data is written to the specified port upon receipt of the  $\overline{\text{WR}}$  signal from the CPU. This signal turns to low level at the rising edge of the  $\overline{\text{WR}}$  and high level at the falling edge of the  $\overline{\text{ACK}}$ .

**$\overline{\text{ACK}}$  (Acknowledge input)**

This signal when turned to low level indicates that the terminal has received data.

**INTR (Interrupt request output)**

This is the signal used to interrupt the CPU when a terminal receives data from the CPU via the MSM82C55A-5. It indicates the occurrence of the interrupt in high level only when the internal INTE flip-flop is set. This signal turns to high level at the rising edge of the  $\overline{\text{ACK}}$  ( $\text{OBF} = 1$  at this time) and low level at the falling edge of  $\overline{\text{WR}}$  when the INTE<sub>B</sub> is set. INTE<sub>A</sub> of group A is set when the bit for PC<sub>6</sub> is set, while INTE<sub>B</sub> of group B is set when the bit for PC<sub>2</sub> is set.

**Mode 1 Input**

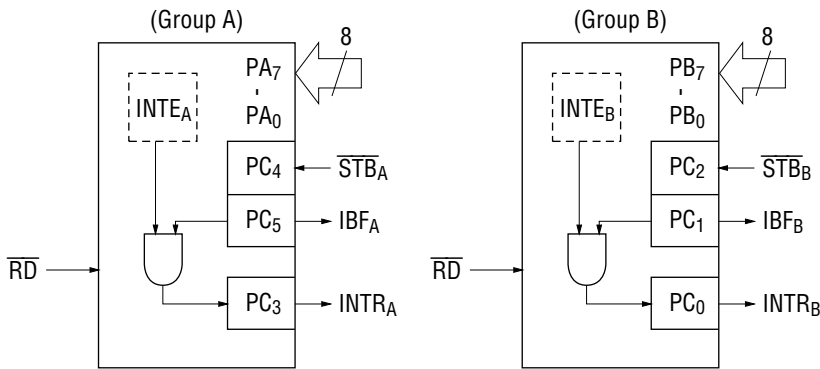

**Note:** Although belonging to group B, PC<sub>3</sub> operates as the control signal of group A functionally.

**Mode 1 Output**

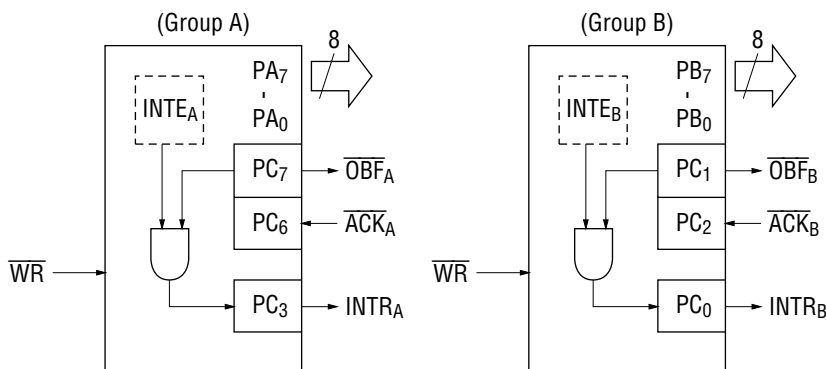

Port C Function Allocation in Mode 1

Combination of Input/Output Port C	Group A: Input Group B: Input	Group A: Input Group B: Output	Group A: Output Group B: Input	Group A: Output Group B: Output
PC <sub>0</sub>	INTR <sub>B</sub>	INTR <sub>B</sub>	INTR <sub>B</sub>	INTR <sub>B</sub>
PC <sub>1</sub>	IBF <sub>B</sub>	$\overline{\text{OBF}}_{\text{B}}$	IBF <sub>B</sub>	$\overline{\text{OBF}}_{\text{B}}$
PC <sub>2</sub>	$\overline{\text{STB}}_{\text{B}}$	$\overline{\text{ACK}}_{\text{B}}$	$\overline{\text{STB}}_{\text{B}}$	$\overline{\text{ACK}}_{\text{B}}$
PC <sub>3</sub>	INTR <sub>A</sub>	INTR <sub>A</sub>	INTR <sub>A</sub>	INTR <sub>A</sub>
PC <sub>4</sub>	$\overline{\text{STB}}_{\text{A}}$	$\overline{\text{STB}}_{\text{A}}$	I/O	I/O
PC <sub>5</sub>	IBF <sub>A</sub>	IBF <sub>A</sub>	I/O	I/O
PC <sub>6</sub>	I/O	I/O	$\overline{\text{ACK}}_{\text{A}}$	$\overline{\text{ACK}}_{\text{A}}$
PC <sub>7</sub>	I/O	I/O	$\overline{\text{OBF}}_{\text{A}}$	$\overline{\text{OBF}}_{\text{A}}$

Note: I/O is a bit not used as the control signal, but it is available as a port of mode 0.

Examples of the relation between the control words and pins when used in mode 1 are shown below:

(a) When group A is mode 1 output and group B is mode 1 input.

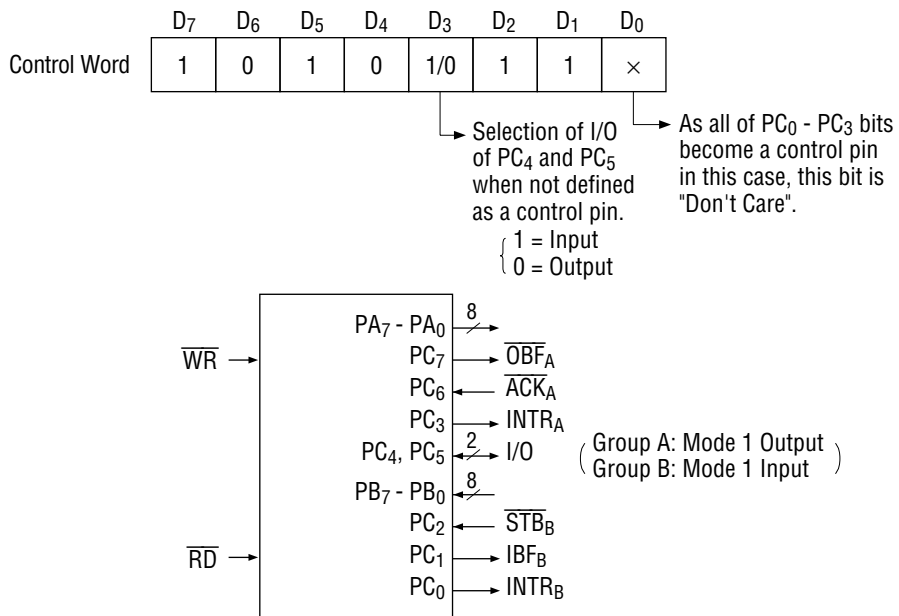

(b) When group A is mode 1 input and group B is mode 1 output.

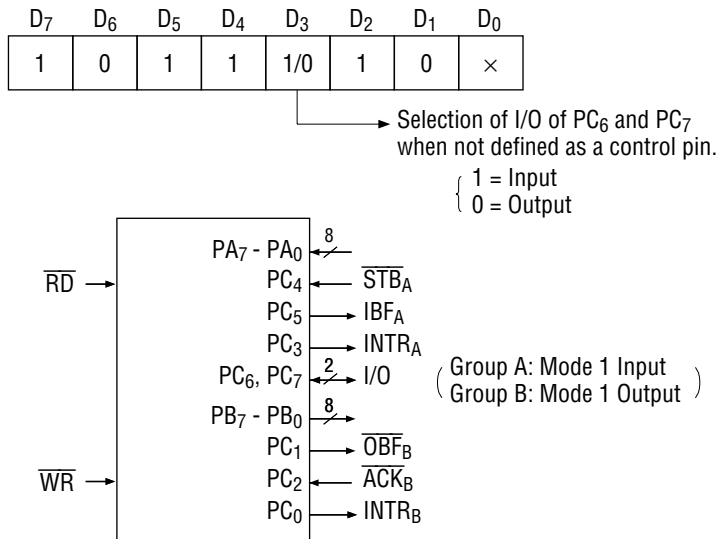

**3. Mode 2 (Strobe bidirectional bus I/O operation)**

In mode 2, it is possible to transfer data in 2 directions through a single 8-bit port. This operation is akin to a combination between input and output operations. Port C waits for the control signal in this case, too. Mode 2 is available only for group A, however. Next, a description is made on mode 2.

**OBF (Output buffer full flag output)**

This signal when turned to low level indicates that data has been written to the internal output latch upon receipt of the WR signal from the CPU. At this time, port A is still in the high impedance status and the data is not yet output to the outside. This signal turns to low level at the rising edge of the WR and high level at the falling edge of the ACK.

**ACK (Acknowledge input)**

When a low level signal is input to this pin, the high impedance status of port A is cleared, the buffer is enabled, and the data written to the internal output latch is output to port A. When the input returns to high level, port A is made into the high impedance status.

**STB (Strobe input)**

When this signal turns to low level, the data output to the port from the pin is fetched into the internal input latch. The data is output to the data bus upon receipt of the RD signal from the CPU, but it remains in the high impedance status until then.

**IBF (Input buffer full flag output)**

This signal when turned to high level indicates that data from the pin has been fetched into the input latch. This signal turns to high level at the falling edge of the STB and low level at the rising edge of the RD.



**INTR (Interrupt request output)**

This signal is used to interrupt the CPU and its operation in the same as in mode 1. There are two INTE flip-flops internally available for input and output to select either interrupt of input or output operation. The INTE1 is used to control the interrupt request for output operation and it can be reset by the bit set for PC6. INTE2 is used to control the interrupt request for the input operation and it can be set by the bit set for PC4.

**Mode 2 I/O Operation**

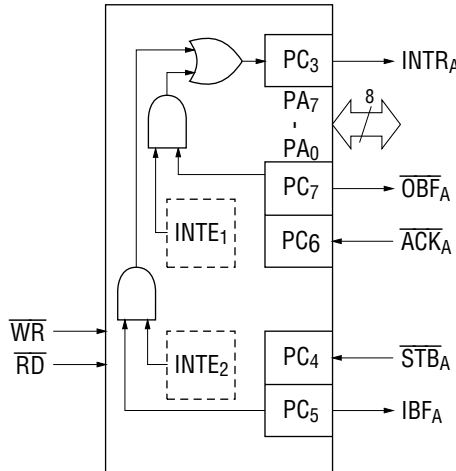

**Port C Function Allocation in Mode 2**

Port C	Function
PC <sub>0</sub>	Confirmed to the Group B Mode
PC <sub>1</sub>	
PC <sub>2</sub>	
PC <sub>3</sub>	INTR <sub>A</sub>
PC <sub>4</sub>	$\overline{STB}_A$
PC <sub>5</sub>	IBF <sub>A</sub>
PC <sub>6</sub>	$\overline{ACK}_A$
PC <sub>7</sub>	$\overline{OBF}_A$

Following is an example of the relation between the control word and the pin when used in mode 2.

When input in mode 2 for group A and in mode 1 for group B.

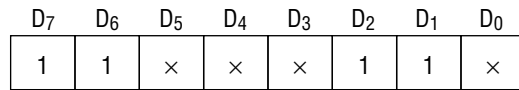

As all of 8 bits of port C become control pins in this case, D<sub>3</sub> and D<sub>0</sub> bits are treated as "Don't Care".

No I/O specification is required for mode 2, since it is a bidirectional operation. This bit is therefore treated as "Don't Care".

When group A is set to mode 2, this bit is treated as "Don't Care".

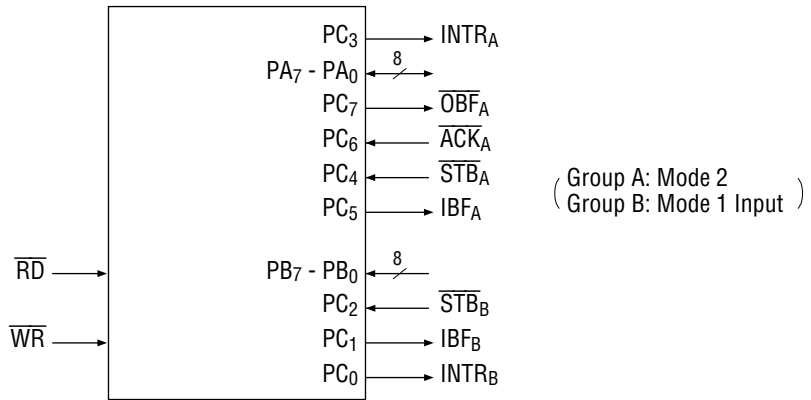

**4. When Group A is Different in Mode from Group B**

Group A and group B can be used by setting them in different modes each other at the same time. When either group is set to mode 1 or mode 2, it is possible to set the one not defined as a control pin in port C to both input and output as port which operates in mode 0 at the 3rd and 0th bits of the control word.

**(Mode combinations that define no control bit at port C)**

	Group A	Group B	Port C							
			PC <sub>7</sub>	PC <sub>6</sub>	PC <sub>5</sub>	PC <sub>4</sub>	PC <sub>3</sub>	PC <sub>2</sub>	PC <sub>1</sub>	PC <sub>0</sub>
1	Mode 1 input	Mode 0	I/O	I/O	IBF <sub>A</sub>	$\overline{STB}_A$	INTR <sub>A</sub>	I/O	I/O	I/O
2	Mode 0 Output	Mode 0	$\overline{OBF}_A$	$\overline{ACK}_A$	I/O	I/O	INTR <sub>A</sub>	I/O	I/O	I/O
3	Mode 0	Mode 1 Input	I/O	I/O	I/O	I/O	I/O	$\overline{STB}_B$	IBF <sub>B</sub>	INTR <sub>B</sub>
4	Mode 0	Mode 1 Output	I/O	I/O	I/O	I/O	I/O	$\overline{ACK}_B$	$\overline{OBF}_B$	INTR <sub>B</sub>
5	Mode 1 Input	Mode 1 Input	I/O	I/O	IBF <sub>A</sub>	$\overline{STB}_A$	INTR <sub>A</sub>	$\overline{STB}_B$	IBF <sub>B</sub>	INTR <sub>B</sub>
6	Mode 1 Input	Mode 1 Output	I/O	I/O	IBF <sub>A</sub>	$\overline{STB}_A$	INTR <sub>A</sub>	$\overline{ACK}_B$	$\overline{OBF}_B$	INTR <sub>B</sub>
7	Mode 1 Output	Mode 1 Input	$\overline{OBF}_A$	$\overline{ACK}_A$	I/O	I/O	INTR <sub>A</sub>	$\overline{STB}_B$	IBF <sub>B</sub>	INTR <sub>B</sub>
8	Mode 1 Output	Mode 1 Output	$\overline{OBF}_A$	$\overline{ACK}_A$	I/O	I/O	INTR <sub>A</sub>	$\overline{ACK}_B$	$\overline{OBF}_B$	INTR <sub>B</sub>
9	Mode 2	Mode 0	$\overline{OBF}_A$	$\overline{ACK}_A$	IBF <sub>A</sub>	$\overline{STB}_A$	INTR <sub>A</sub>	I/O	I/O	I/O

Controlled at the 3rd bit (D<sub>3</sub>) of  
the Control Word

Controlled at the 0th bit (D<sub>0</sub>) of  
the Control Word

When the I/O bit is set to input in this case, it is possible to access data by the normal port C read operation.

When set to output, PC<sub>7</sub>-PC<sub>4</sub> bits can be accessed by the bit set/reset function only.

Meanwhile, 3 bits from PC<sub>2</sub> to PC<sub>0</sub> can be accessed by normal write operation.

The bit set/reset function can be used for all of PC<sub>3</sub>-PC<sub>0</sub> bits. Note that the status of port C varies according to the combination of modes like this.

### 5. Port C Status Read

When port C is used for the control signal, that is, in either mode 1 or mode 2, each control signal and bus status signal can be read out by reading the content of port C. The status read out is as follows:

	Group A	Group B	Status Read on the Data Bus							
			D <sub>7</sub>	D <sub>6</sub>	D <sub>5</sub>	D <sub>4</sub>	D <sub>3</sub>	D <sub>2</sub>	D <sub>1</sub>	D <sub>0</sub>
1	Mode 1 Input	Mode 0	I/O	I/O	IBF <sub>A</sub>	INTE <sub>A</sub>	INTR <sub>A</sub>	I/O	I/O	I/O
2	Mode 1 Output	Mode 0	$\overline{\text{OBF}}_A$	INTE <sub>A</sub>	I/O	I/O	INTR <sub>A</sub>	I/O	I/O	I/O
3	Mode 0	Mode 1 Input	I/O	I/O	I/O	I/O	I/O	INTE <sub>B</sub>	IBF <sub>B</sub>	INTR <sub>B</sub>
4	Mode 0	Mode 1 Output	I/O	I/O	I/O	I/O	I/O	INTE <sub>B</sub>	$\overline{\text{OBF}}_B$	INTR <sub>B</sub>
5	Mode 1 Input	Mode 1 Input	I/O	I/O	IBF <sub>A</sub>	INTE <sub>A</sub>	INTR <sub>A</sub>	INTE <sub>B</sub>	IBF <sub>B</sub>	INTR <sub>B</sub>
6	Mode 1 Input	Mode 1 Output	I/O	I/O	IBF <sub>A</sub>	INTE <sub>A</sub>	INTR <sub>A</sub>	INTE <sub>B</sub>	$\overline{\text{OBF}}_B$	INTR <sub>B</sub>
7	Mode 1 Output	Mode 1 Input	$\overline{\text{OBF}}_A$	INTE <sub>A</sub>	I/O	I/O	INTR <sub>A</sub>	INTE <sub>B</sub>	IBF <sub>B</sub>	INTR <sub>B</sub>
8	Mode 1 Output	Mode 1 Output	$\overline{\text{OBF}}_A$	INTE <sub>A</sub>	I/O	I/O	INTR <sub>A</sub>	INTE <sub>B</sub>	$\overline{\text{OBF}}_B$	INTR <sub>B</sub>
9	Mode 2	Mode 0	$\overline{\text{OBF}}_A$	INTE <sub>1</sub>	IBF <sub>A</sub>	INTE <sub>2</sub>	INTR <sub>A</sub>	I/O	I/O	I/O
10	Mode 2	Mode 1 Input	$\overline{\text{OBF}}_A$	INTE <sub>1</sub>	IBF <sub>A</sub>	INTE <sub>2</sub>	INTR <sub>A</sub>	INTE <sub>B</sub>	IBF <sub>B</sub>	INTR <sub>B</sub>
11	Mode 2	Mode 1 Output	$\overline{\text{OBF}}_A$	INTE <sub>1</sub>	IBF <sub>A</sub>	INTE <sub>2</sub>	INTR <sub>A</sub>	INTE <sub>B</sub>	$\overline{\text{OBF}}_B$	INTR <sub>B</sub>

### 6. Reset of MSM82C55A-2

Be sure to keep the RESET signal at power ON in the high level at least for 50 μs. Subsequently, it becomes the input mode at a high level pulse above 500 ns.

#### Note: Comparison of MSM82C55A-5 and MSM82C55A-2

##### MSM82C55A-5

After a write command is executed to the command register, the internal latch is cleared in PORTA PORTC. For instance, 00H is output at the beginning of a write command when the output port is assigned. However, if PORTB is not cleared at this time, PORTB is unstable. In other words, PORTB only outputs ineffective data (unstable value according to the device) during the period from after a write command is executed till the first data is written to PORTB.

##### MSM82C55A-2

After a write command is executed to the command register, the internal latch is cleared in All Ports (PORTA, PORTB, PORTC). 00H is output at the beginning of a write command when the output port is assigned.

**NOTICE ON REPLACING LOW-SPEED DEVICES WITH HIGH-SPEED DEVICES**

The conventional low speed devices are replaced by high-speed devices as shown below. When you want to replace your low speed devices with high-speed devices, read the replacement notice given on the next pages.

<b>High-speed device (New)</b>	<b>Low-speed device (Old)</b>	<b>Remarks</b>
M80C85AH	M80C85A/M80C85A-2	8bit MPU
M80C86A-10	M80C86A/M80C86A-2	16bit MPU
M80C88A-10	M80C88A/M80C88A-2	8bit MPU
M82C84A-2	M82C84A/M82C84A-5	Clock generator
M81C55-5	M81C55	RAM.I/O, timer
M82C37B-5	M82C37A/M82C37A-5	DMA controller
M82C51A-2	M82C51A	USART
M82C53-2	M82C53-5	Timer
M82C55A-2	M82C55A-5	PPI

## Differences between MSM82C55A-5 and MSM82C55A-2

### 1) Manufacturing Process

These devices use a 3  $\mu$  Si-Gate CMOS process technology.

The MSM82C55A-2 is about 7% smaller in chip size than the MSM82C55A-5 as the MSM82C55A-2 changed its output characteristics.

### 2) Function

Item	MSM82C55A-5	MSM82C55A-2
Internal latch during writing into the command register	Only ports A and C are cleared. Port B is not cleared.	All ports are cleared.

The above function has been improved to remove bugs and other logics are not different between the two devices.

### 3) Electrical Characteristics

#### 3-1) DC Characteristics

Parameter	Symbol	MSM82C55A-5	MSM82C55A-2
"L" Output Voltage	V <sub>OL</sub>	0.45 V (I <sub>oL</sub> = +2.5 mA)	0.40 V (I <sub>oL</sub> = +2.5 mA)
"H" Output Voltage	V <sub>OH</sub>	2.4 V (I <sub>oH</sub> = -400 $\mu$ A)	3.7 V (I <sub>oH</sub> = -2.5 mA)
Average Operating Current	I <sub>CC</sub>	5 mA maximum (I/O Cycle = 1 $\mu$ s)	8 mA maximum (I/O Cycle = 375 ns)

As shown above, the DC characteristics of the MSM82C55A-2 satisfies the DC characteristics of the MSM82C55A-5.

#### 3-2) AC Characteristics

Parameter	Symbol	MSM82C55A-5	MSM82C55A-2
Address Hold Time for $\overline{RD}$ Rising	t <sub>RA</sub>	20 ns minimum	0 ns minimum
$\overline{RD}$ Pulse Width	t <sub>RR</sub>	300 ns minimum	100 ns minimum
Defined Data Output Delay Time From $\overline{RD}$ Falling	t <sub>RD</sub>	200 ns maximum	120 ns maximum
Data Floating Delay Time From $\overline{RD}$ Rising	t <sub>RF</sub>	100 ns maximum	75 ns maximum
RD/WR Recovery Time	t <sub>RV</sub>	850 ns minimum	200 ns minimum

Parameter	Symbol	MSM82C55A-5	MSM82C55A-2
Address Hold Time for $\overline{WR}$ Rising	tWA	30 ns minimum	20 ns minimum
$\overline{WR}$ Pulse Width	tWW	300 ns minimum	150 ns minimum
Data Setup Time for $\overline{WR}$ Rising	tDW	1000 ns minimum	50 ns minimum
Data Hold Time for $\overline{WR}$ Rising	tWD	40 ns minimum	30 ns minimum
Defined Data Output Time From $\overline{WR}$ Rising	tWB	350 ns maximum	200 ns maximum
Port Data Hold Time for $\overline{RD}$ Rising	tHR	20 ns minimum	10 ns minimum
$\overline{ACK}$ Pulse Width	tAK	300 ns minimum	100 ns minimum
$\overline{STB}$ Pulse Width	tST	300 ns minimum	100 ns minimum
Port Data Hold Time for $\overline{STB}$ Falling	tPH	180 ns minimum	50 ns minimum
$\overline{ACK}$ Falling to Defined Data Output	tAD	300 ns maximum	150 ns maximum
$\overline{WR}$ Falling to $\overline{OBF}$ Falling Delay Time	tWOB	650 ns maximum	150 ns maximum
$\overline{ACK}$ Falling to $\overline{OBF}$ Rising Delay Time	tAOB	350 ns maximum	150 ns maximum
$\overline{STB}$ Falling to IBF Rising Delay Time	tsIB	300 ns maximum	150 ns maximum
$\overline{RD}$ Rising to IBF Falling Delay Time	trIB	300 ns maximum	150 ns maximum
$\overline{RD}$ Falling to INTR Falling Delay Time	trIT	400 ns maximum	200 ns maximum
$\overline{STB}$ Rising to INTR Rising Delay Time	tsIT	300 ns maximum	150 ns maximum
$\overline{ACK}$ Rising to INTR Rising Delay Time	tAIT	350 ns maximum	150 ns maximum
$\overline{WR}$ Falling to INTR Falling Delay Time	twIT	850 ns minimum	250 ns maximum

As shown above, the MSM82C55A-2 satisfies the characteristics of the MSM82C55A-5.

PACKAGE DIMENSIONS

(Unit : mm)

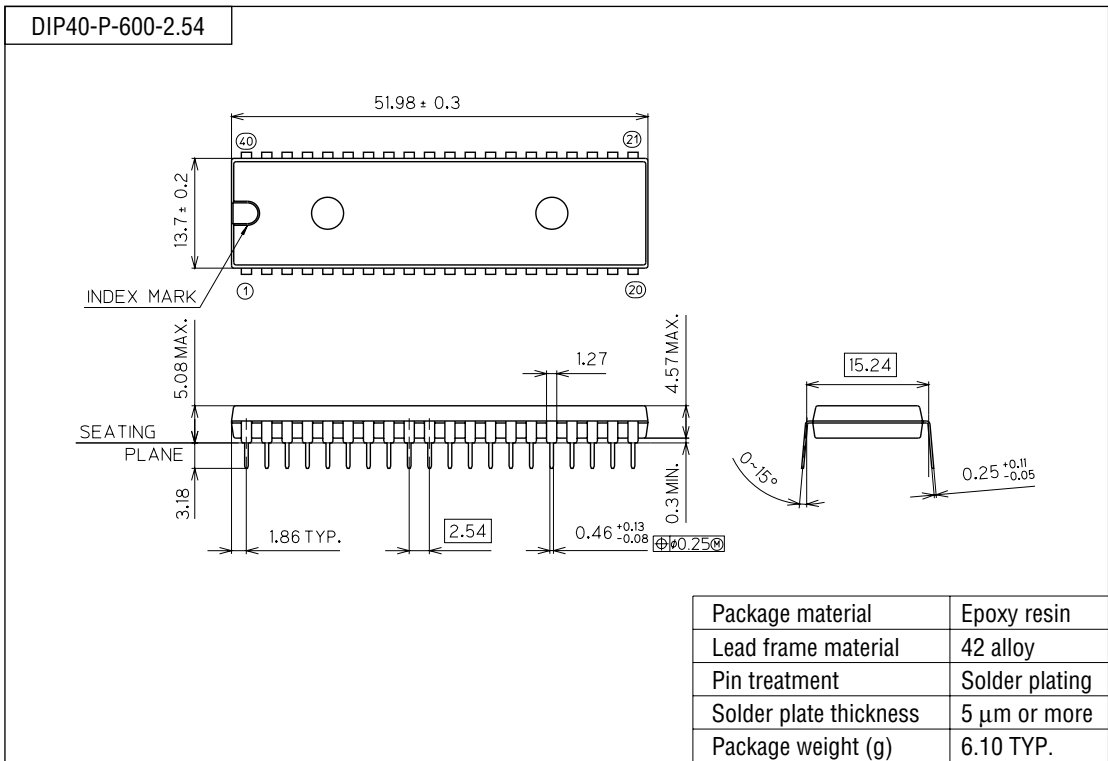

Notes for Mounting the Surface Mount Type Package

The SOP, QFP, TSOP, SOJ, QFJ (PLCC), SHP and BGA are surface mount type packages, which are very susceptible to heat in reflow mounting and humidity absorbed in storage. Therefore, before you perform reflow mounting, contact Oki's responsible sales person for the product name, package name, pin number, package code and desired mounting conditions (reflow method, temperature and times).



(Unit : mm)

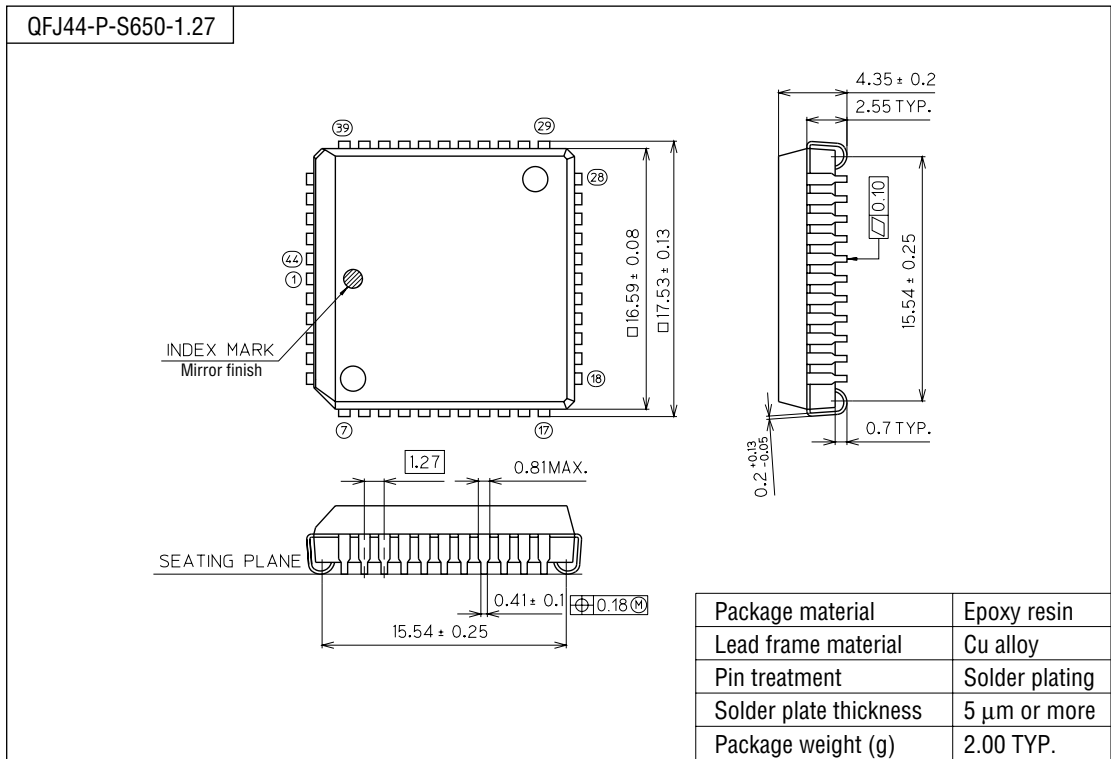

Notes for Mounting the Surface Mount Type Package

The SOP, QFP, TSOP, SOJ, QFJ (PLCC), SHP and BGA are surface mount type packages, which are very susceptible to heat in reflow mounting and humidity absorbed in storage. Therefore, before you perform reflow mounting, contact Oki's responsible sales person for the product name, package name, pin number, package code and desired mounting conditions (reflow method, temperature and times).

(Unit : mm)

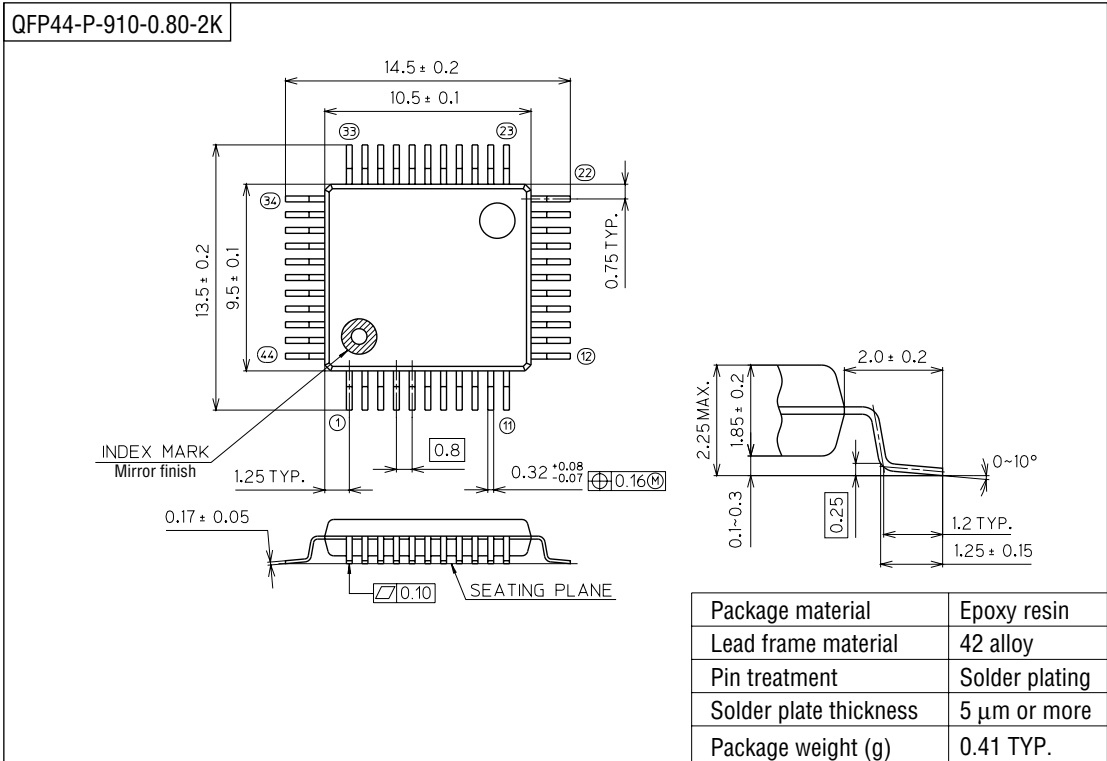

Notes for Mounting the Surface Mount Type Package

The SOP, QFP, TSOP, SOJ, QFJ (PLCC), SHP and BGA are surface mount type packages, which are very susceptible to heat in reflow mounting and humidity absorbed in storage. Therefore, before you perform reflow mounting, contact Oki's responsible sales person for the product name, package name, pin number, package code and desired mounting conditions (reflow method, temperature and times).