

Single-Channel: 6N135, 6N136, HCPL2503, HCPL4502

Dual-Channel: HCPL2530, HCPL2531

High Speed Transistor Optocouplers

Features

- High speed –1 MBit/s
- Superior CMR – 10kV/μs
- Dual-Channel HCPL2530/HCPL2531
- Double working voltage – 480V RMS
- CTR guaranteed 0–70°C
- U.L. recognized (File # E90700)

Applications

- Line receivers
- Pulse transformer replacement
- Output interface to CMOS-LSTTL-TTL
- Wide bandwidth analog coupling

Description

The HCPL4502, HCPL2503, 6N135, 6N136, HCPL2530 and HCPL2531 optocouplers consist of an AlGaAs LED optically coupled to a high speed photodetector transistor.

A separate connection for the bias of the photodiode improves the speed by several orders of magnitude over conventional phototransistor optocouplers by reducing the base-collector capacitance of the input transistor.

An internal noise shield provides superior common mode rejection of 10kV/μs. An improved package allows superior insulation permitting a 480V working voltage compared to industry standard of 220V.

Schematics

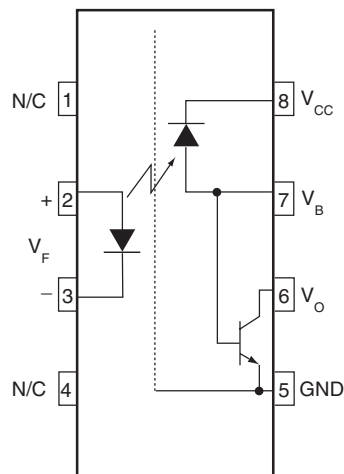

6N135, 6N136, HCPL2503, HCPL4502

Pin 7 is not connected in
Part Number HCPL4502

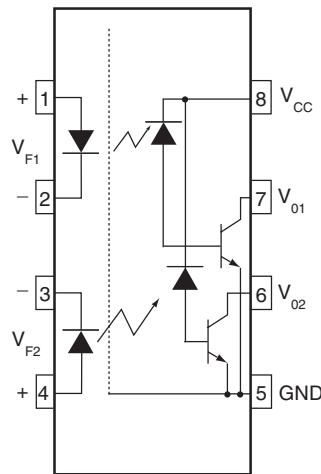

HCPL2530/HCPL2531

Package Outlines

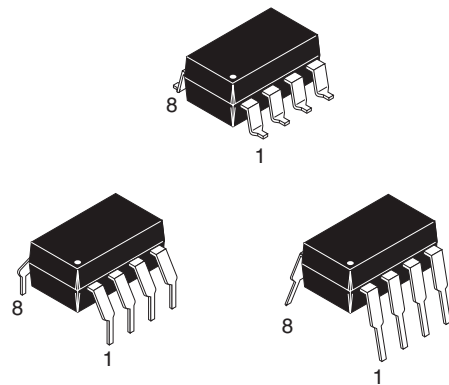

Absolute Maximum Ratings ($T_A = 25^\circ\text{C}$ unless otherwise specified)

Stresses exceeding the absolute maximum ratings may damage the device. The device may not function or be operable above the recommended operating conditions and stressing the parts to these levels is not recommended. In addition, extended exposure to stresses above the recommended operating conditions may affect device reliability. The absolute maximum ratings are stress ratings only.

Symbol	Parameter	Condition	Value	Units
T_{STG}	Storage Temperature		-55 to +125	$^\circ\text{C}$
T_{OPR}	Operating Temperature		-55 to +100	$^\circ\text{C}$
T_{SOL}	Lead Solder Temperature		260 for 10 sec	$^\circ\text{C}$
EMITTER				
I_F (avg)	DC/Average Forward Input Current Each Channel ⁽¹⁾		25	mA
I_F (pk)	Peak Forward Input Current Each Channel ⁽²⁾	50% duty cycle, 1ms P.W.	50	mA
I_F (trans)	Peak Transient Input Current Each Channel	$\leq 1\mu\text{s}$ P.W., 300pps	1.0	A
V_R	Reverse Input Voltage Each Channel		5	V
P_D	Input Power Dissipation Each Channel	6N135/6N136 and HCPL2503/4502	100	mW
		HCPL-2530/253 ⁽³⁾	45	
DETECTOR				
I_O (avg)	Average Output Current Each Channel		8	mA
I_O (pk)	Peak Output Current Each Channel		16	mA
V_{EBR}	Emitter-Base Reverse Voltage	6N135, 6N136 and HCPL2503 only	5	V
V_{CC}	Supply Voltage		-0.5 to 30	V
V_O	Output Voltage		-0.5 to 20	V
I_B	Base Current	6N135, 6N136 and HCPL2503 only	5	mA
PD	Output Power Dissipation Each Channel	6N135, 6N136, HCPL2503, HCPL4502 ⁽⁴⁾	100	mW
		HCPL2530, HCPL2531	35	mW

Notes:

1. Derate linearly above 70°C free-air temperature at a rate of $0.8\text{mA}/^\circ\text{C}$.
2. Derate linearly above 70°C free-air temperature at a rate of $1.6\text{mA}/^\circ\text{C}$.
3. Derate linearly above 70°C free-air temperature at a rate of $0.9\text{mW}/^\circ\text{C}$.
4. Derate linearly above 70°C free-air temperature at a rate of $2.0\text{mW}/^\circ\text{C}$.

Electrical Characteristics ($T_A = 0$ to 70°C Unless otherwise specified)**Individual Component Characteristics**

Symbol	Parameter	Test Conditions	Device	Min.	Typ.*	Max.	Unit
EMITTER							
V_F	Input Forward Voltage	$I_F = 16\text{mA}$, $T_A = 25^\circ\text{C}$			1.45	1.7	V
		$I_F = 16\text{mA}$				1.8	
B_{VR}	Input Reverse Breakdown Voltage	$I_R = 10\ \mu\text{A}$		5.0			V
$\Delta V_F/\Delta T_A$	Temperature Coefficient of Forward Voltage	$I_F = 16\text{mA}$			-1.6		mV/ $^\circ\text{C}$
DETECTOR							
I_{OH}	Logic High Output Current	$I_F = 0\text{mA}$, $V_O = V_{CC} = 5.5\text{V}$, $T_A = 25^\circ\text{C}$	All		0.001	0.5	μA
		$I_F = 0\text{mA}$, $V_O = V_{CC} = 15\text{V}$, $T_A = 25^\circ\text{C}$	6N135 6N136 HCPL4502 HCPL2503		0.005	1	
		$I_F = 0\text{mA}$, $V_O = V_{CC} = 15\text{V}$	All			50	
I_{CCL}	Logic Low Supply Current	$I_F = 16\text{mA}$, $V_O = \text{Open}$, $V_{CC} = 15\text{V}$	6N135 6N136 HCPL4502 HCPL2503		120	200	μA
		$I_{F1} = I_{F2} = 16\text{mA}$, $V_O = \text{Open}$, $V_{CC} = 15\text{V}$	HCPL2530 HCPL2531		200	400	
I_{CCH}	Logic High Supply Current	$I_F = 0\text{mA}$, $V_O = \text{Open}$, $V_{CC} = 15\text{V}$, $T_A = 25^\circ\text{C}$	6N135 6N136 HCPL4502 HCPL2503			1	μA
		$I_F = 0\text{mA}$, $V_O = \text{Open}$, $V_{CC} = 15\text{V}$	6N135 6N136 HCPL4502 HCPL2503			2	
		$I_F = 0\text{mA}$, $V_O = \text{Open}$, $V_{CC} = 15\text{V}$	HCPL2530 HCPL2531		0.02	4	

*All Typical at $T_A = 25^\circ\text{C}$

Electrical Characteristics (Continued) ($T_A = 0$ to 70°C unless otherwise specified)**Transfer Characteristics**

Symbol	Parameter	Test Conditions	Device	Min.	Typ.*	Max.	Unit	
COUPLED								
CTR	Current Transfer Ratio ⁽⁵⁾	$I_F = 16\text{mA}$, $V_O = 0.4\text{V}$, $V_{CC} = 4.5\text{V}$, $T_A = 25^\circ\text{C}$	6N135 HCPL2530	7	18	50	%	
			6N136 HCPL4502 HCPL2531	19	27	50	%	
			HCPL2503	12	27		%	
		$I_F = 16\text{mA}$, $V_{CC} = 4.5\text{V}$	$V_{OL} = 0.4\text{V}$	6N135	5	21		%
			$V_{OL} = 0.5\text{V}$	HCPL2530				
			$V_{OL} = 0.4\text{V}$	6N136 HCPL4502	15	30		%
			$V_{OL} = 0.5\text{V}$	HCPL2531				
$V_{OL} = 0.4\text{V}$	HCPL2503	9	30		%			
V_{OL}	Logic LOW Output Voltage	$I_F = 16\text{mA}$, $I_O = 1.1\text{mA}$, $V_{CC} = 4.5\text{V}$, $T_A = 25^\circ\text{C}$	6N135		0.18	0.4	V	
			HCPL2530		0.18	0.5		
		$I_F = 16\text{mA}$, $I_O = 3\text{mA}$, $V_{CC} = 4.5\text{V}$, $T_A = 25^\circ\text{C}$	6N136 HCPL2503		0.25	0.4		
			HCPL2531		0.25	0.5		
		$I_F = 16\text{mA}$, $I_O = 0.8\text{mA}$, $V_{CC} = 4.5\text{V}$	6N135 HCPL2530			0.5		
$I_F = 16\text{mA}$, $I_O = 2.4\text{mA}$, $V_{CC} = 4.5\text{V}$	HCPL4502 HCPL2531			0.5				

*All Typical at $T_A = 25^\circ\text{C}$ **Note:**

5. Current Transfer Ratio is defined as a ratio of output collector current, I_O , to the forward LED input current, I_F , times 100%.

Electrical Characteristics (Continued) ($T_A = 0$ to 70°C unless otherwise specified)**Switching Characteristics** ($V_{CC} = 5\text{V}$)

Symbol	Parameter	Test Conditions	Device	Min.	Typ.*	Max.	Unit
T_{PHL}	Propagation Delay Time to Logic LOW	$T_A = 25^\circ\text{C}$, $R_L = 4.1\text{k}\Omega$, $I_F = 16\text{mA}^{(6)}$ (Fig. 7)	6N135 HCPL2530		0.45	1.5	μs
		$R_L = 1.9\text{k}\Omega$, $I_F = 16\text{mA}$, $T_A = 25^\circ\text{C}^{(7)}$ (Fig. 7)	6N136 HCPL4502 HCPL2503 HCPL2531		0.45	0.8	μs
		$R_L = 4.1\text{k}\Omega$, $I_F = 16\text{mA}^{(6)}$ (Fig. 7)	6N135 HCPL2530			2.0	μs
		$R_L = 1.9\text{k}\Omega$, $I_F = 16\text{mA}^{(7)}$ (Fig. 7)	6N136 HCPL4502 HCPL2503 HCPL2531			1.0	μs
T_{PLH}	Propagation Delay Time to Logic HIGH	$T_A = 25^\circ\text{C}$, ($R_L = 4.1\text{k}\Omega$, $I_F = 16\text{mA}^{(6)}$) (Fig. 7)	6N135 HCPL2530		0.5	1.5	μs
		$R_L = 1.9\text{k}\Omega$, $I_F = 16\text{mA}^{(7)}$ (Fig. 7) $T_A = 25^\circ\text{C}$	6N136 HCPL4502 HCPL2503 HCPL2531		0.3	0.8	μs
		$R_L = 4.1\text{k}\Omega$, $I_F = 16\text{mA}^{(6)}$ (Fig. 7)	6N135 HCPL2530			2.0	μs
		$R_L = 1.9\text{k}\Omega$, $I_F = 16\text{mA}^{(7)}$ (Fig. 7)	6N136 HCPL4502 HCPL2503 HCPL2531			1.0	μs
ICM_{HI}	Common Mode Transient Immunity at Logic High	$I_F = 0\text{mA}$, $V_{CM} = 10V_{P-P}$, $R_L = 4.1\text{k}\Omega$, $T_A = 25^\circ\text{C}^{(8)}$ (Fig. 8)	6N135 HCPL2530		10,000		$\text{V}/\mu\text{s}$
		$I_F = 0\text{mA}$, $V_{CM} = 10V_{P-P}$, $R_L = 1.9\text{k}\Omega$, $T_A = 25^\circ\text{C}^{(8)}$ (Fig. 8)	6N136 HCPL4502 HCPL2503 HCPL2531		10,000		$\text{V}/\mu\text{s}$
ICM_{LI}	Common Mode Transient Immunity at Logic Low	$I_F = 16\text{mA}$, $V_{CM} = 10V_{P-P}$, $R_L = 4.1\text{k}\Omega$, $T_A = 25^\circ\text{C}^{(8)}$ (Fig. 8)	6N135 HCPL2530		10,000		$\text{V}/\mu\text{s}$
		$I_F = 16\text{mA}$, $V_{CM} = 10V_{P-P}$, $R_L = 1.9\text{k}\Omega^{(8)}$ (Fig. 8)	6N136 HCPL4502 HCPL2503 HCPL2531		10,000		$\text{V}/\mu\text{s}$

** All Typical at $T_A = 25^\circ\text{C}$ **Notes:**

- The $4.1\text{k}\Omega$ load represents 1 LSTTL unit load of 0.36mA and $6.1\text{k}\Omega$ pull-up resistor.
- The $1.9\text{k}\Omega$ load represents 1 TTL unit load of 1.6mA and $5.6\text{k}\Omega$ pull-up resistor.
- Common mode transient immunity in logic high level is the maximum tolerable (positive) dV_{cm}/dt on the leading edge of the common mode pulse signal V_{CM} , to assure that the output will remain in a logic high state (i.e., $V_O > 2.0\text{V}$). Common mode transient immunity in logic low level is the maximum tolerable (negative) dV_{cm}/dt on the trailing edge of the common mode pulse signal, V_{CM} , to assure that the output will remain in a logic low state (i.e., $V_O < 0.8\text{V}$).

Electrical Characteristics (Continued) ($T_A = 0$ to 70°C unless otherwise specified)**Isolation Characteristics** ($T_A = 0$ to 70°C Unless otherwise specified)

Symbol	Characteristics	Test Conditions	Min	Typ**	Max	Unit
I_{I-O}	Input-Output Insulation Leakage Current	Relative humidity = 45%, $T_A = 25^\circ\text{C}$, $t = 5\text{s}$, $V_{I-O} = 3000\text{VDC}^{(9)}$			1.0	μA
V_{ISO}	Withstand Insulation Test Voltage	$RH \leq 50\%$, $T_A = 25^\circ\text{C}$, $I_{I-O} \leq 2\mu\text{A}$, $t = 1\text{min.}^{(9)}$	2500			V_{RMS}
R_{I-O}	Resistance (Input to Output)	$V_{I-O} = 500\text{VDC}^{(9)}$		10^{12}		Ω
C_{I-O}	Capacitance (Input to Output)	$f = 1\text{MHz}^{(9)}$		0.6		pF
HFE	DC Current Gain	$I_O = 3\text{mA}$, $V_O = 5\text{V}^{(9)}$		150		
I_{I-I}	Input-Input Insulation Leakage Current	$RH \leq 45\%$, $V_{I-I} = 500\text{VDC}^{(10)}$ $t = 5\text{s}$, (HCPL2530/2531 only)		0.005		μA
R_{I-I}	Input-Input Resistance	$V_{I-I} = 500\text{VDC}^{(10)}$ (HCPL2530/2531 only)		10^{11}		Ω
C_{I-I}	Input-Input Capacitance	$f = 1\text{MHz}^{(10)}$ (HCPL2530/2531 only)		0.03		pF

Notes:

9. Device is considered a two terminal device: Pins 1, 2, 3 and 4 are shorted together and Pins 5, 6, 7 and 8 are shorted together.
10. Measured between pins 1 and 2 shorted together, and pins 3 and 4 shorted together.

Typical Performance Curves

Fig. 1 Normalized CTR vs. Forward Current

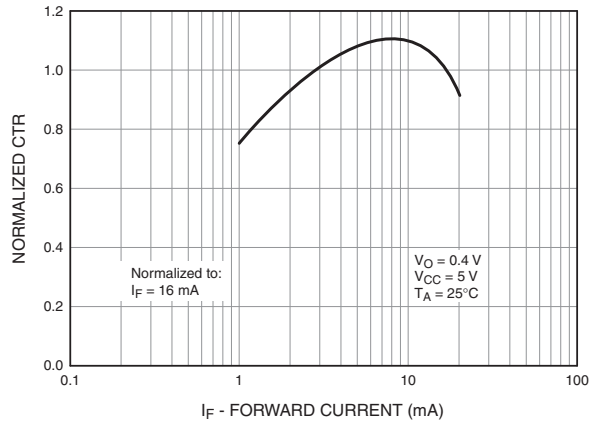

Fig. 2 Normalized CTR vs. Temperature

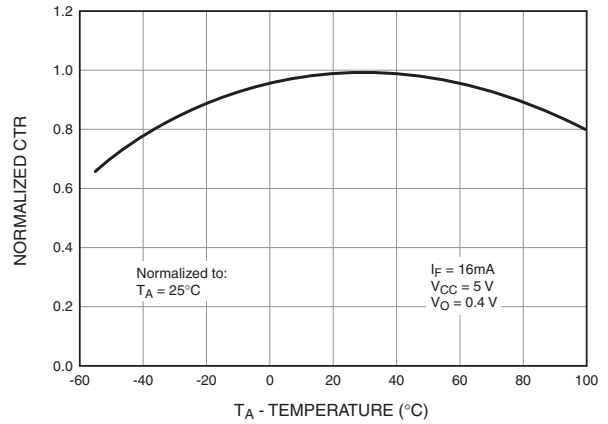

Fig. 3 Output Current vs. Output Voltage

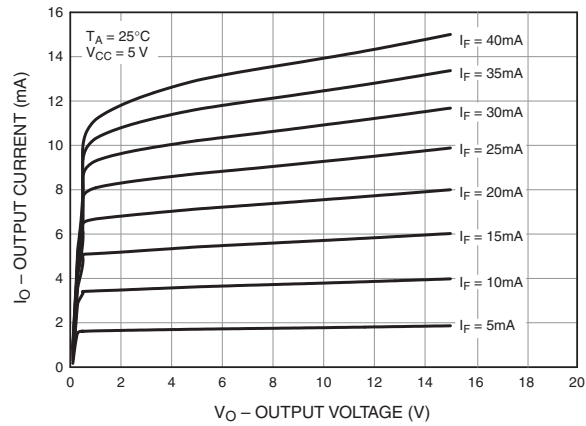

Fig. 4 Logic High Output Current vs. Temperature

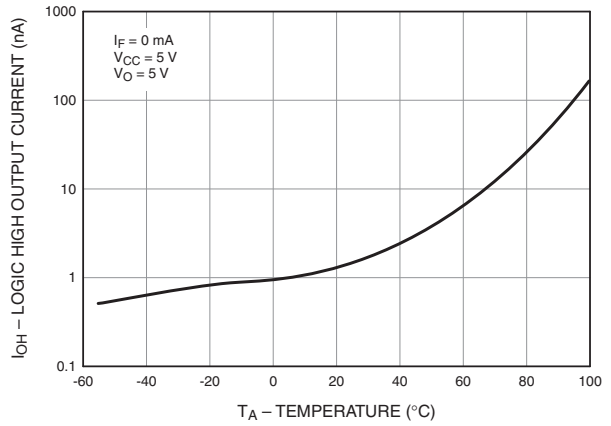

Fig. 5 Propagation Delay vs. Temperature

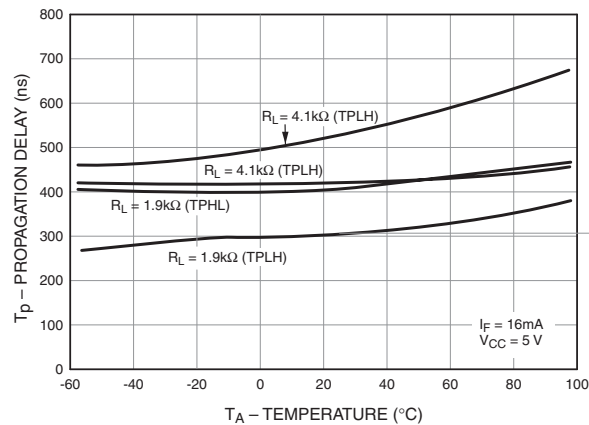
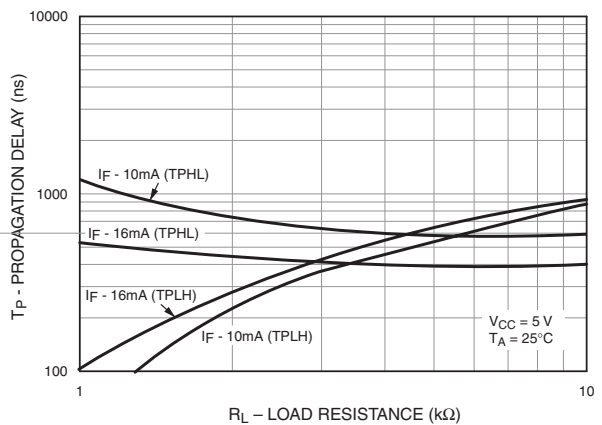
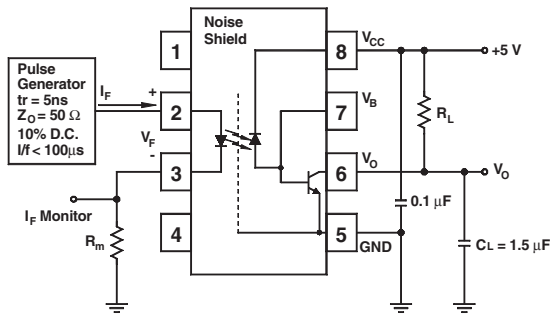

Fig. 6 Propagation Delay vs. Load Resistance



Test Circuits



Test Circuit for 6N135, 6N136, HCPL-2503 and HCPL-4502

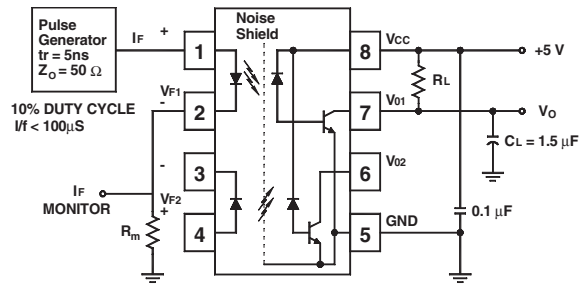

Test Circuit for HCPL-2530 and HCPL-2531

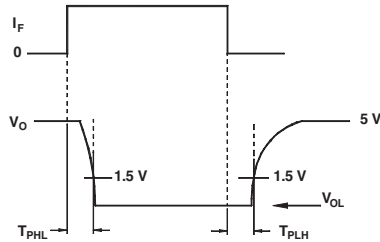
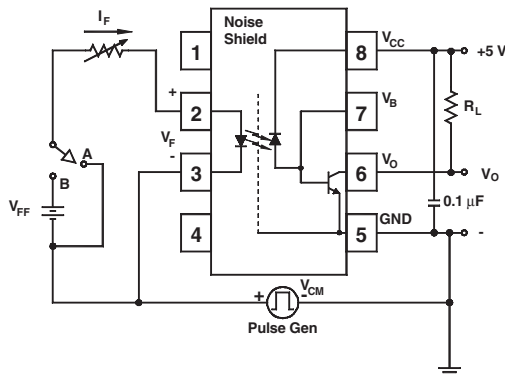
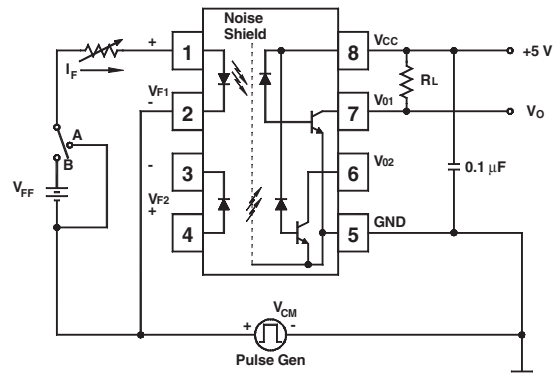

Fig. 7 Switching Time Test Circuit



Test Circuit for 6N135, 6N136, HCPL-2503 and HCPL-4502



Test Circuit for HCPL-2530 and HCPL-2531

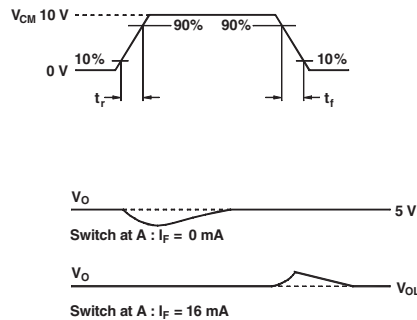
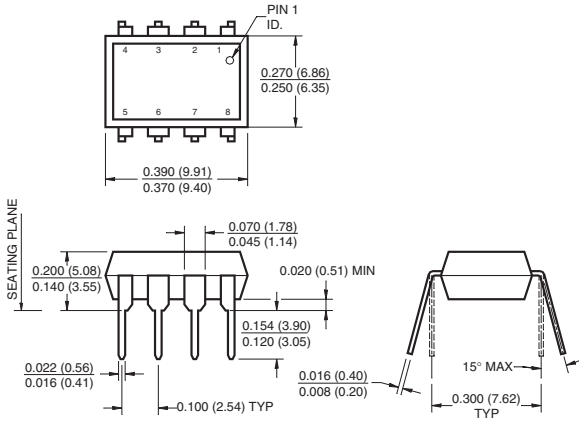

Fig. 8 Common Mode Immunity Test Circuit

Package Dimensions

Through Hole



0.4" Lead Spacing

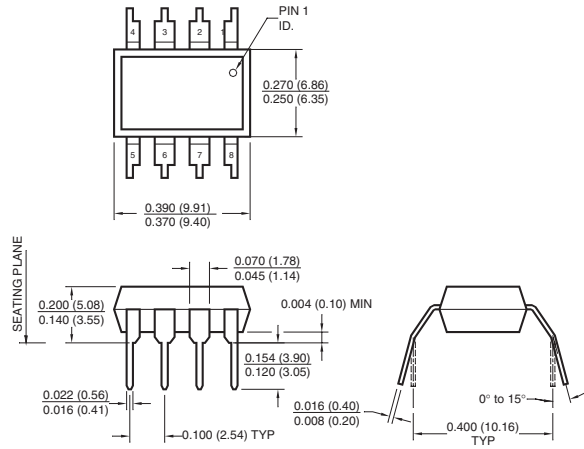

Surface Mount

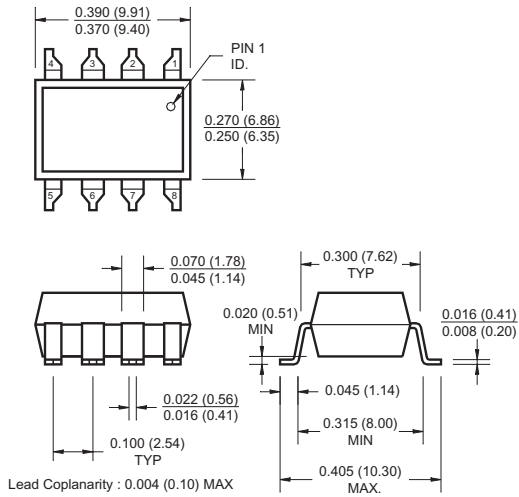

8-Pin DIP – Land Pattern

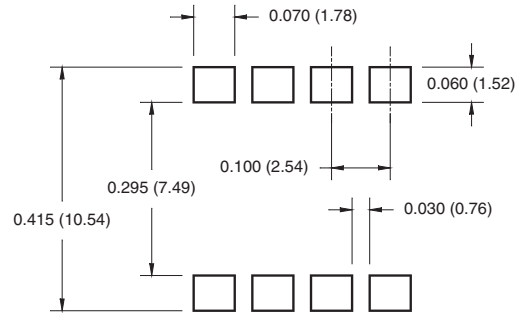

Note:

All dimensions are in inches (millimeters)

Ordering Information

Option	Example Part Number	Description
S	6N135S	Surface Mount Lead Bend
SD	6N135SD	Surface Mount; Tape and reel
W	6N135W	0.4" Lead Spacing
V	6N135V	VDE0884
WV	6N135WV	VDE0884; 0.4" lead spacing
SV	6N135SV	VDE0884; surface mount
SDV	6N135SDV	VDE0884; surface mount; tape and reel

Marking Information

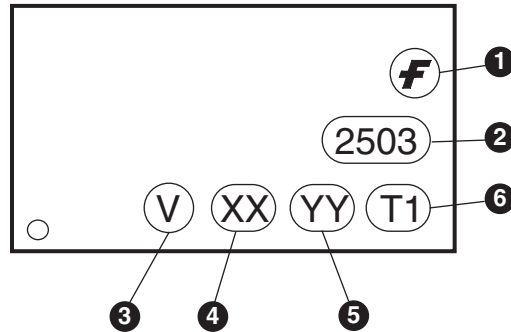

Definitions	
1	Fairchild logo
2	Device number
3	VDE mark (Note: Only appears on parts ordered with VDE option – See order entry table)
4	Two digit year code, e.g., '03'
5	Two digit work week ranging from '01' to '53'
6	Assembly package code

Tape Specifications

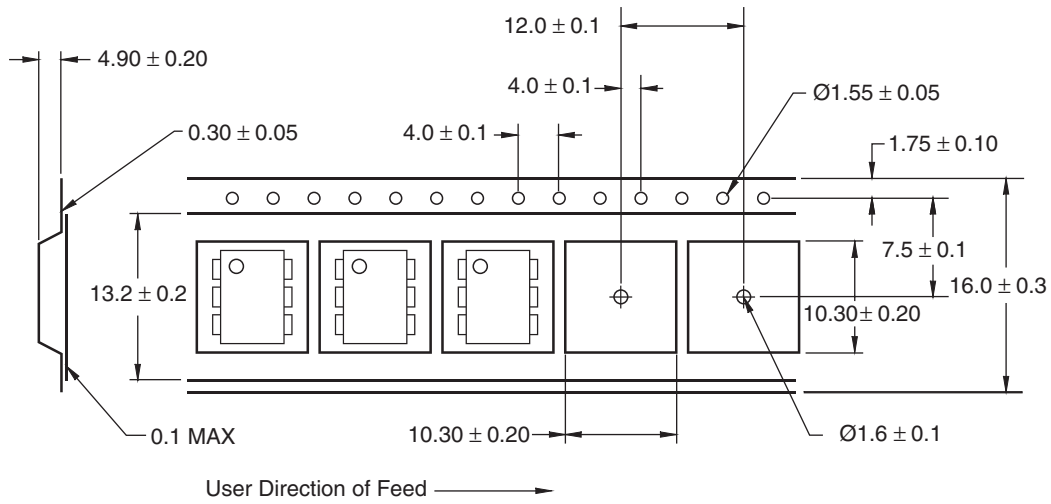

Reflow Profile

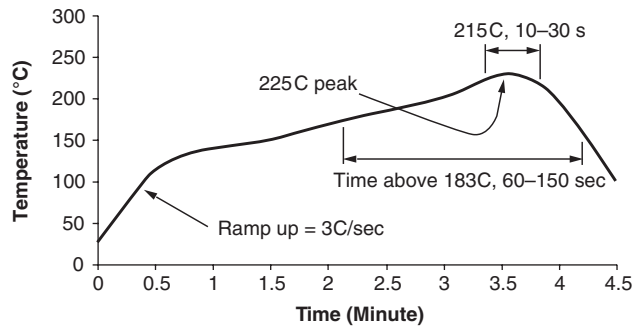

- Peak reflow temperature: 225C (package surface temperature)
- Time of temperature higher than 183C for 60-150 seconds
- One time soldering reflow is recommended