

LED-180-10200

➤ **Features:**

- Single color
- High Power output
- Low power consumption
- High reliability and long life

➤ **Descriptions:**

- Dice material: AlGaAs
- Emitting Color: Infrared Emitting diodes
- Device Outline:  $\phi$  5mm Round Type
- Lens Type: Black Transparent

➤ **Directivity:**

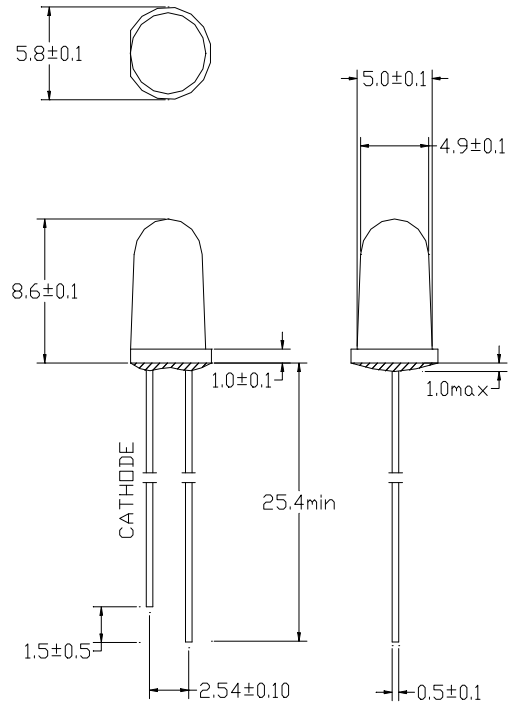

● Tolerance is +/-0.25mm unless otherwise noted

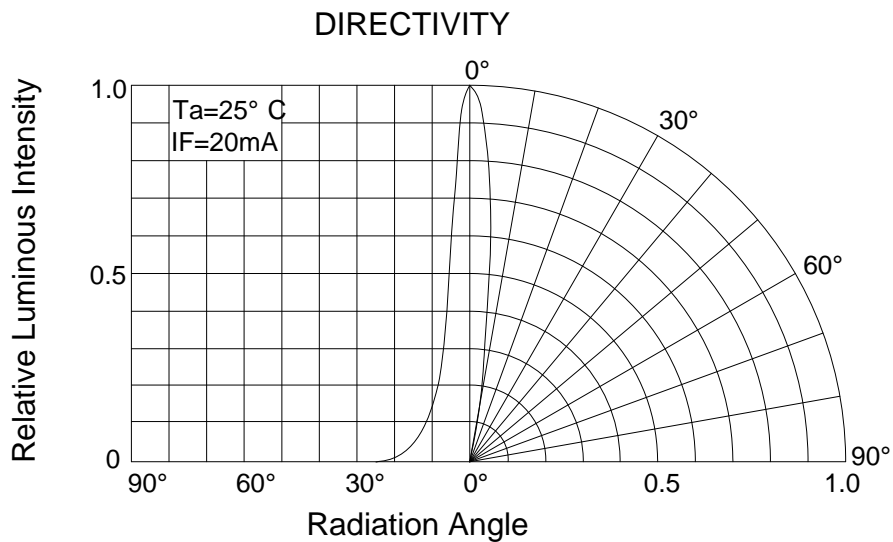

## LED SPECIFICATION

### ➤ Absolute maximum ratings (Ta = 25°C)

Parameter	Symbol	Test Conditions	Characteristics		Unit
			Min.	Max.	
Power Dissipation	$P_d$	—	—	100	mW
Reverse Voltage	$V_R$	$I_R=10\ \mu\text{A}$	9	—	V
Forward Current	$I_{FM}$	Duty=0.01mS 1kHz	—	1000	mA
Operating Temperature Range	$T_{opr}$	—	-40	+85	°C
Storage Temperature Range	$T_{str}$	—	-40	+100	°C
Soldering Temperature	$T_{sd}$	$t \leq 5\text{sec}, 2\text{mm from case}$	—	260	°C

### ➤ Electrical and optical characteristics (Ta = 25°C)

Parameter	Symbol	Test Condition	Value			Unit
			Min.	Typ.	Max.	
Forward Voltage	$V_F$	$I_F = 50\text{mA}$	----	1.55	1.8	V
Reverse Current	$I_R$	$V_R = 9\text{V}$	----	----	10	$\mu\text{A}$
Peak Wavelength	$\lambda_p$	$I_F = 50\text{mA}$	----	850	----	nm
Spectrum Width of Half Value	$\Delta\lambda$	$I_F = 50\text{mA}$	—	45	—	nm
Radiant Intensity	$I_e$	$I_F=50\text{mA}$	—	160	—	mW/Sr
Viewing Angle	$2\theta_{1/2}$	$I_F = 50\text{mA}$	----	13	----	Deg.

## ➤ Typical electrical/optical characteristic curves:

